

# MinBD: Minimally-Buffered Deflection Routing for Energy-Efficient Interconnect

**Chris Fallin**, Greg Nazario, Xiangyao Yu\*,  
Kevin Chang, Rachata Ausavarungrun, Onur Mutlu

Carnegie Mellon University

\*CMU and Tsinghua University

**SAFARI** Carnegie Mellon University

# Motivation

---

- In many-core chips, on-chip interconnect (NoC) consumes **significant power**

**Intel Terascale:** ~28% of chip power

**Intel SCC:** ~10%

**MIT RAW:** ~36%

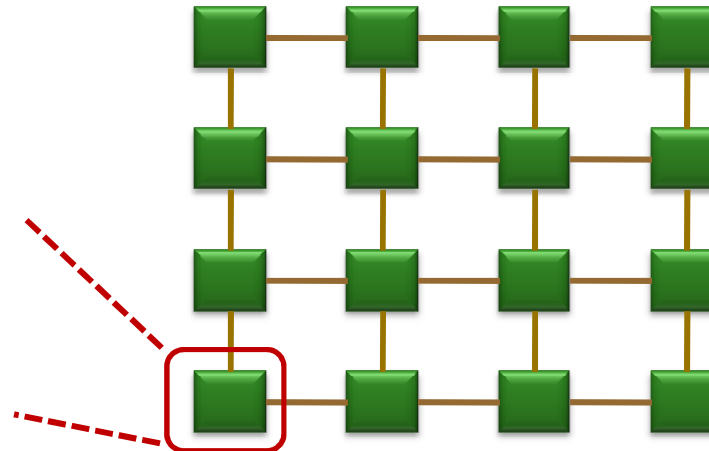

- Recent work<sup>1</sup> uses **bufferless deflection routing** to reduce power and die area

---

<sup>1</sup>Moscibroda and Mutlu, "A Case for Bufferless Deflection Routing in On-Chip Networks." ISCA 2009.

# Bufferless Deflection Routing

---

- **Key idea:** Packets are never buffered in the network. When two packets contend for the same link, one is **deflected**.
  - Removing **buffers** yields significant benefits
    - Reduces **power** (CHIPPER: reduces NoC power by 55%)
    - Reduces **die area** (CHIPPER: reduces NoC area by 36%)
  - But, at **high network utilization** (load), bufferless deflection routing causes **unnecessary link & router traversals**
    - Reduces **network throughput** and application performance
    - Increases **dynamic power**
  - **Goal:** Improve **high-load performance** of low-cost deflection networks by reducing the deflection rate.
-

# Outline: This Talk

---

- **Motivation**
- **Background:** Bufferless Deflection Routing
- **MinBD:** Reducing Deflections
  - Addressing Link Contention
  - Addressing the Ejection Bottleneck
  - Improving Deflection Arbitration
- **Results**
- **Conclusions**

# Outline: This Talk

---

- **Motivation**
- **Background:** Bufferless Deflection Routing
- **MinBD:** Reducing Deflections
  - Addressing Link Contention
  - Addressing the Ejection Bottleneck
  - Improving Deflection Arbitration
- **Results**
- **Conclusions**

# Bufferless Deflection Routing

- **Key idea:** Packets are never buffered in the network. When two packets contend for the same link, one is **deflected**.<sup>1</sup>

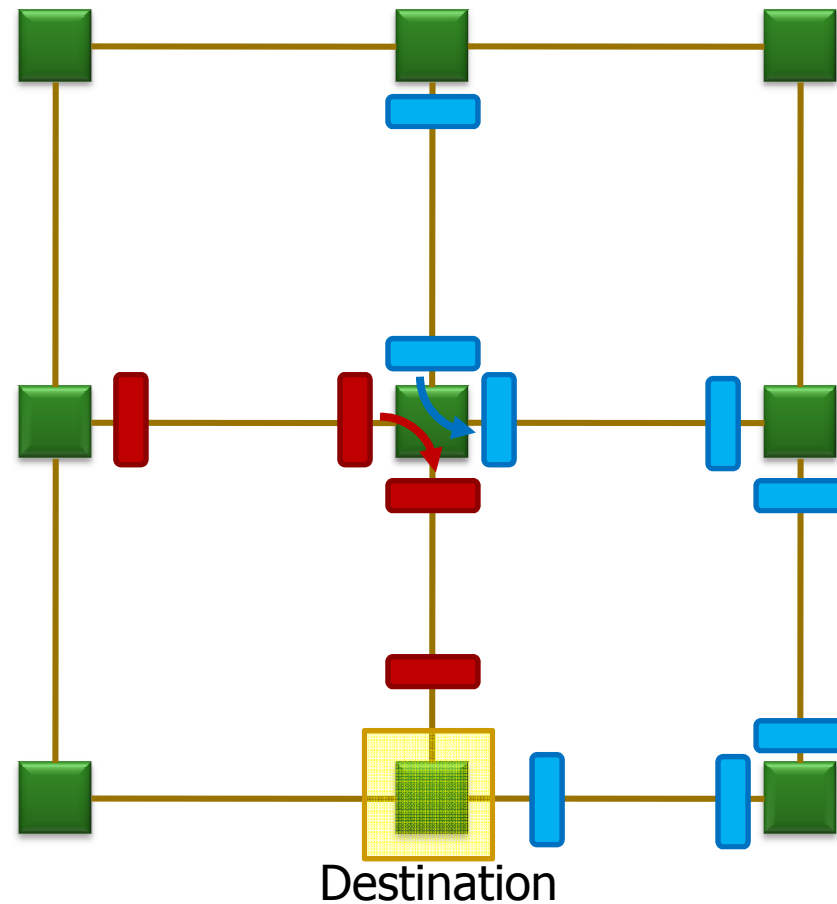

<sup>1</sup>Baran, "On Distributed Communication Networks." RAND Tech. Report., 1962 / IEEE Trans.Comm., 1964. 6

# Bufferless Deflection Routing

---

- Input buffers are eliminated: flits are buffered in **pipeline latches** and on **network links**

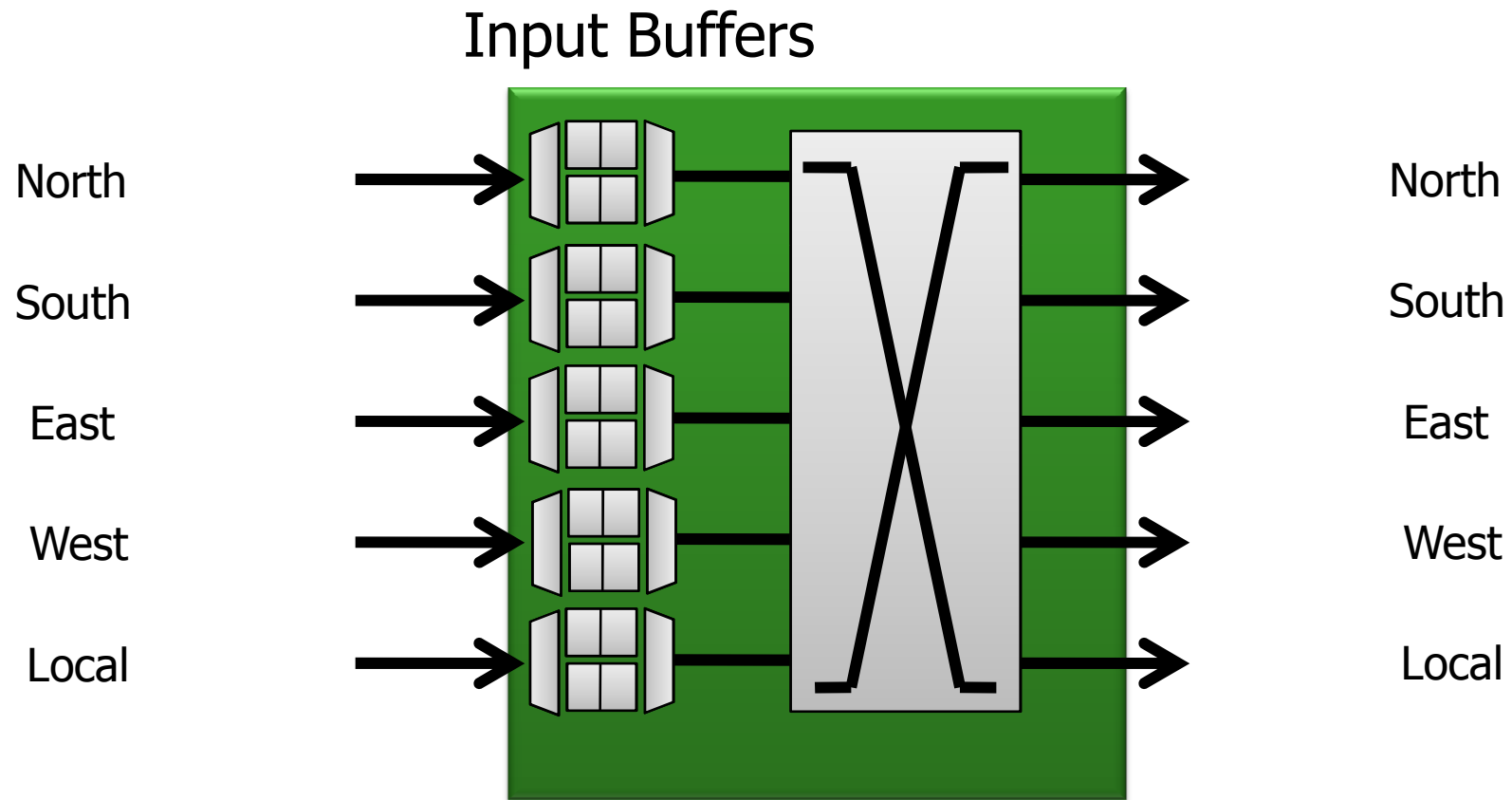

# Bufferless Deflection Routing

---

- Input buffers are eliminated: flits are buffered in **pipeline latches** and on **network links**

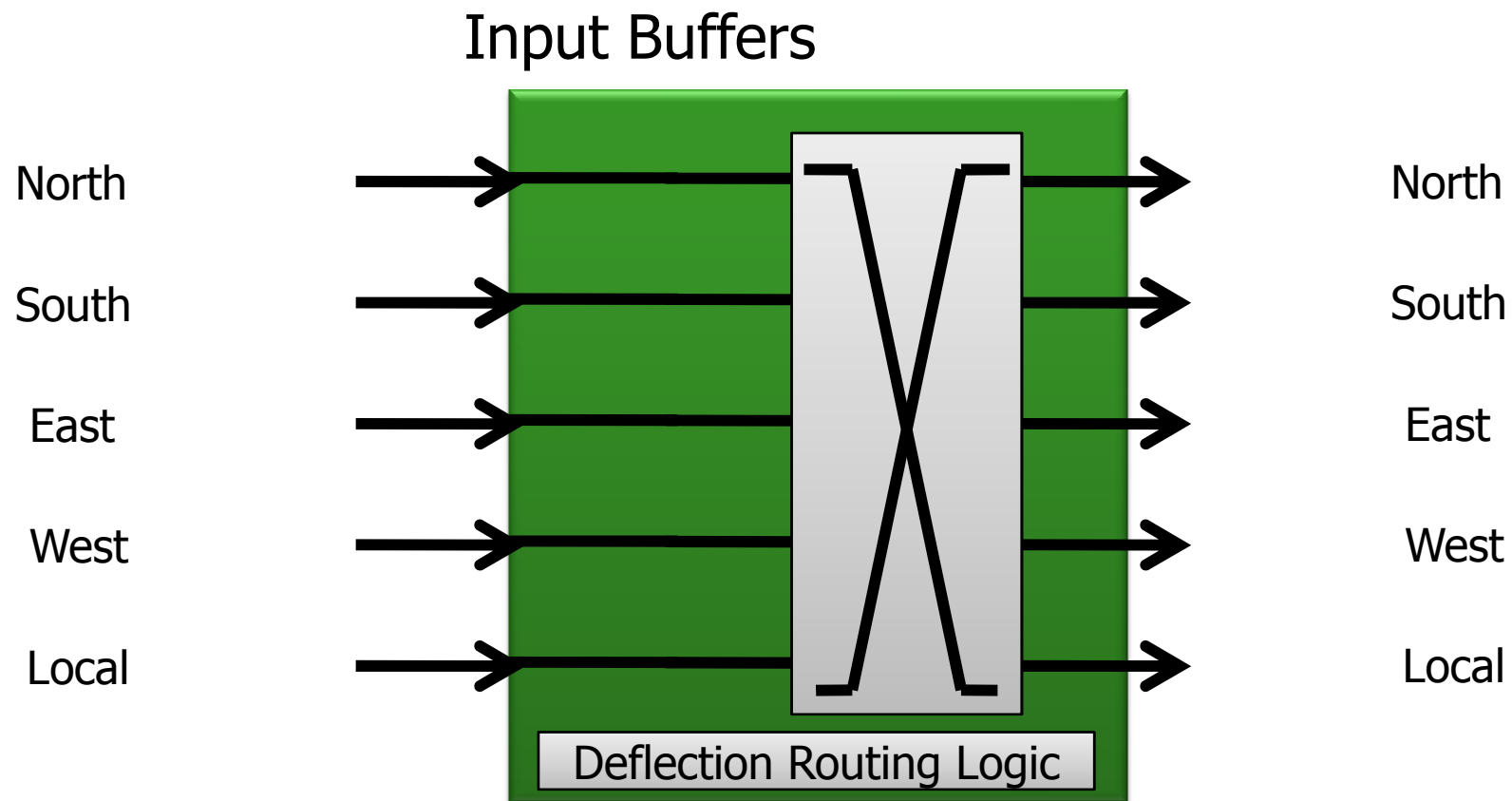



# Deflection Router Microarchitecture

---

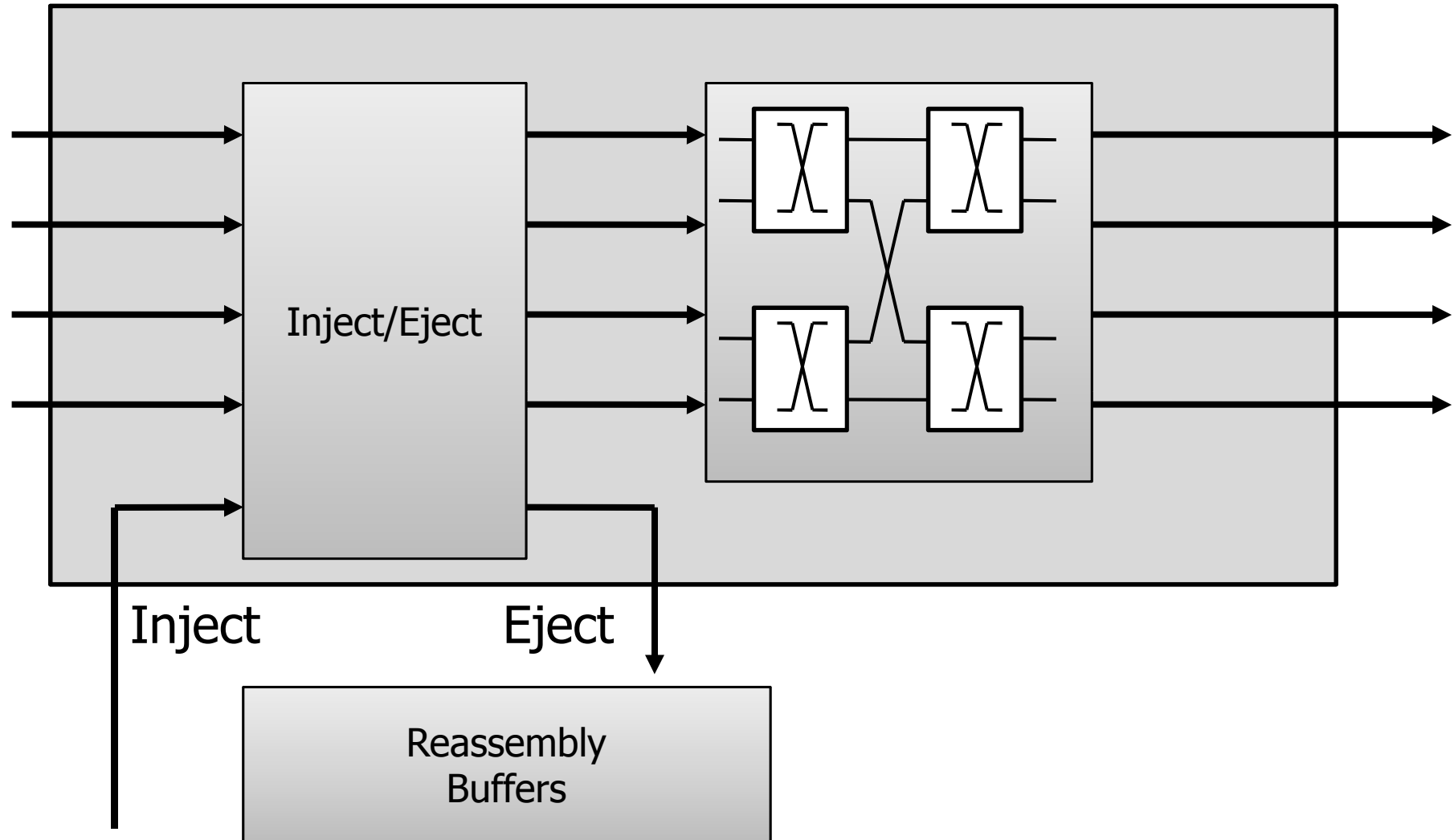

# Deflection Router Microarchitecture

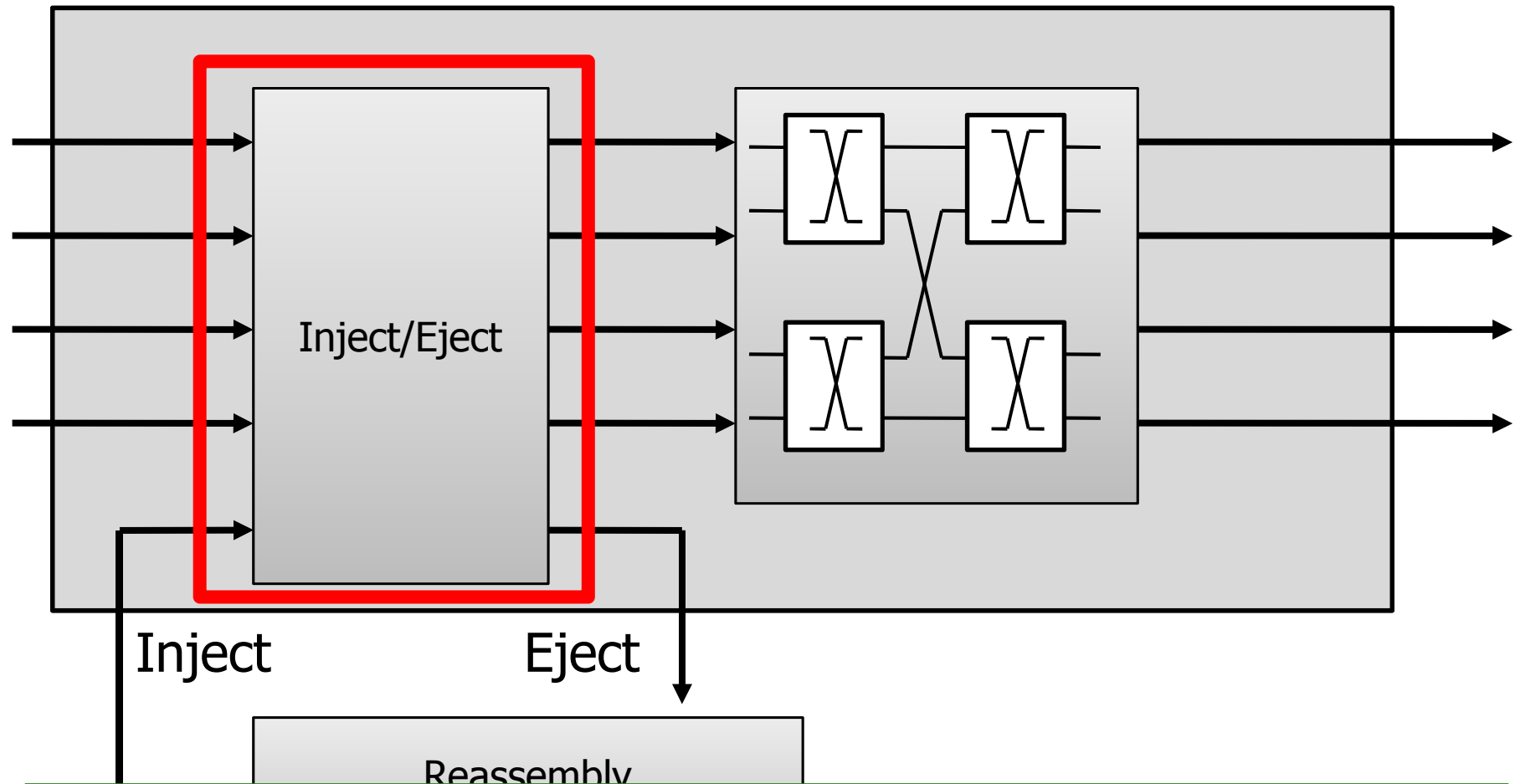

**Stage 1: Ejection and injection of local traffic**

# Deflection Router Microarchitecture

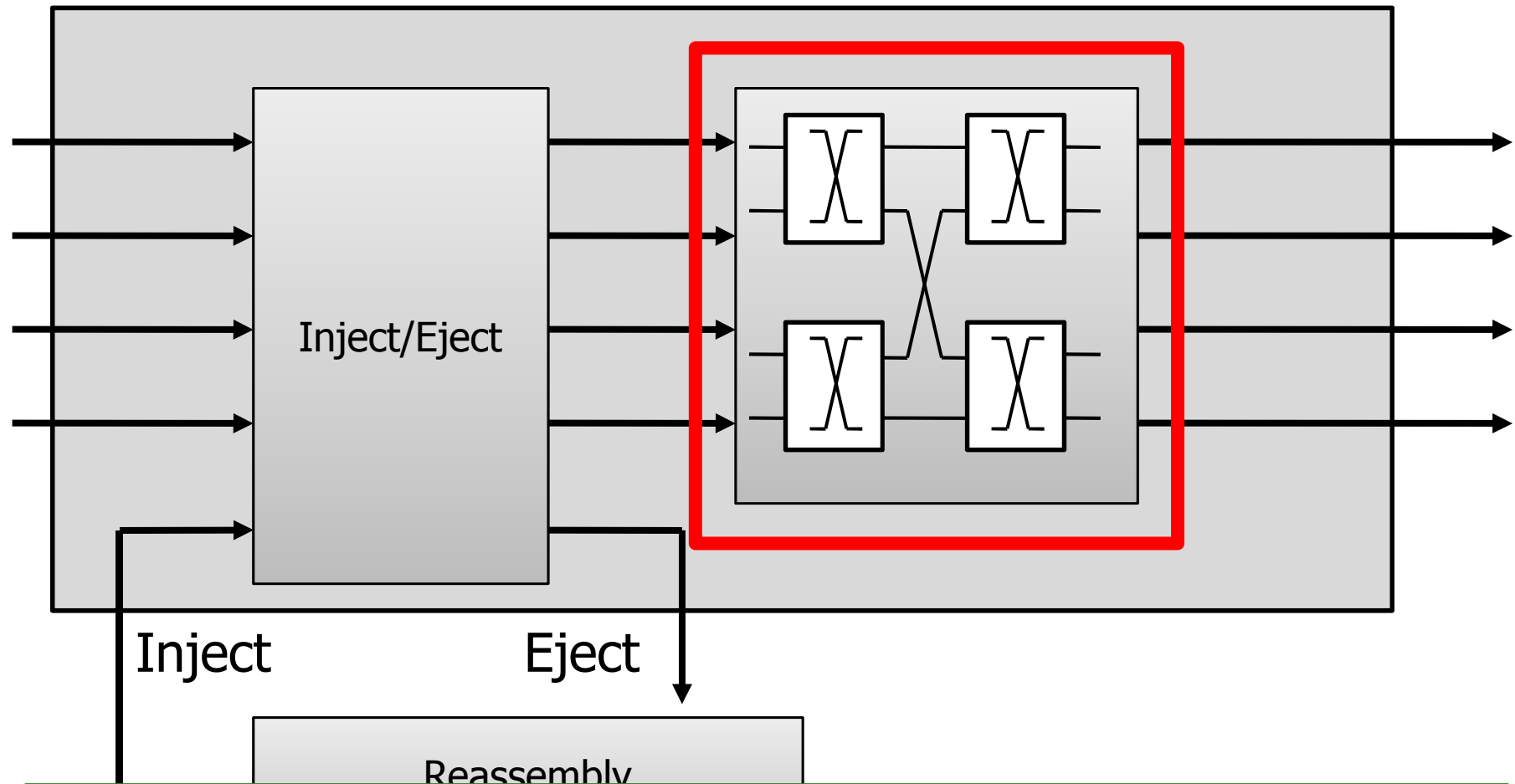

## Stage 2: Deflection arbitration

# Issues in Bufferless Deflection Routing

---

- **Correctness:** Deliver all packets without **livelock**
  - **CHIPPER<sup>1</sup>: Golden Packet**
  - **Globally prioritize one packet** until delivered
- **Correctness:** Reassemble packets without **deadlock**
  - **CHIPPER<sup>1</sup>: Retransmit-Once**
- **Performance:** Avoid performance degradation at **high load**
  - **MinBD**

---

<sup>1</sup> Fallin et al., "CHIPPER: A Low-complexity Bufferless Deflection Router", HPCA 2011. <sup>12</sup>

# Key Performance Issues

---

- 1. Link contention:** no buffers to hold traffic → any link contention causes a deflection  
→ use side buffers
- 2. Ejection bottleneck:** only one flit can eject per router per cycle → simultaneous arrival causes deflection  
→ eject up to 2 flits/cycle
- 3. Deflection arbitration:** practical (fast) deflection arbiters deflect unnecessarily  
→ new priority scheme (silver flit)

# Outline: This Talk

---

- **Motivation**
- **Background:** Bufferless Deflection Routing
- **MinBD:** Reducing Deflections
  - Addressing Link Contention
  - Addressing the Ejection Bottleneck
  - Improving Deflection Arbitration
- **Results**
- **Conclusions**

# Outline: This Talk

---

- **Motivation**
- **Background:** Bufferless Deflection Routing
- **MinBD:** Reducing Deflections
  - Addressing Link Contention
  - Addressing the Ejection Bottleneck
  - Improving Deflection Arbitration
- **Results**
- **Conclusions**

# Addressing Link Contention

---

- **Problem 1:** Any link contention causes a deflection
- **Buffering** a flit can avoid deflection on contention
- But, **input buffers** are expensive:
  - All flits are buffered on every hop → **high dynamic energy**
  - Large buffers necessary → **high static energy** and **large area**
- **Key Idea 1:** add a **small buffer** to a bufferless deflection router to buffer **only** flits that **would have been deflected**



# How to Buffer Deflected Flits

---

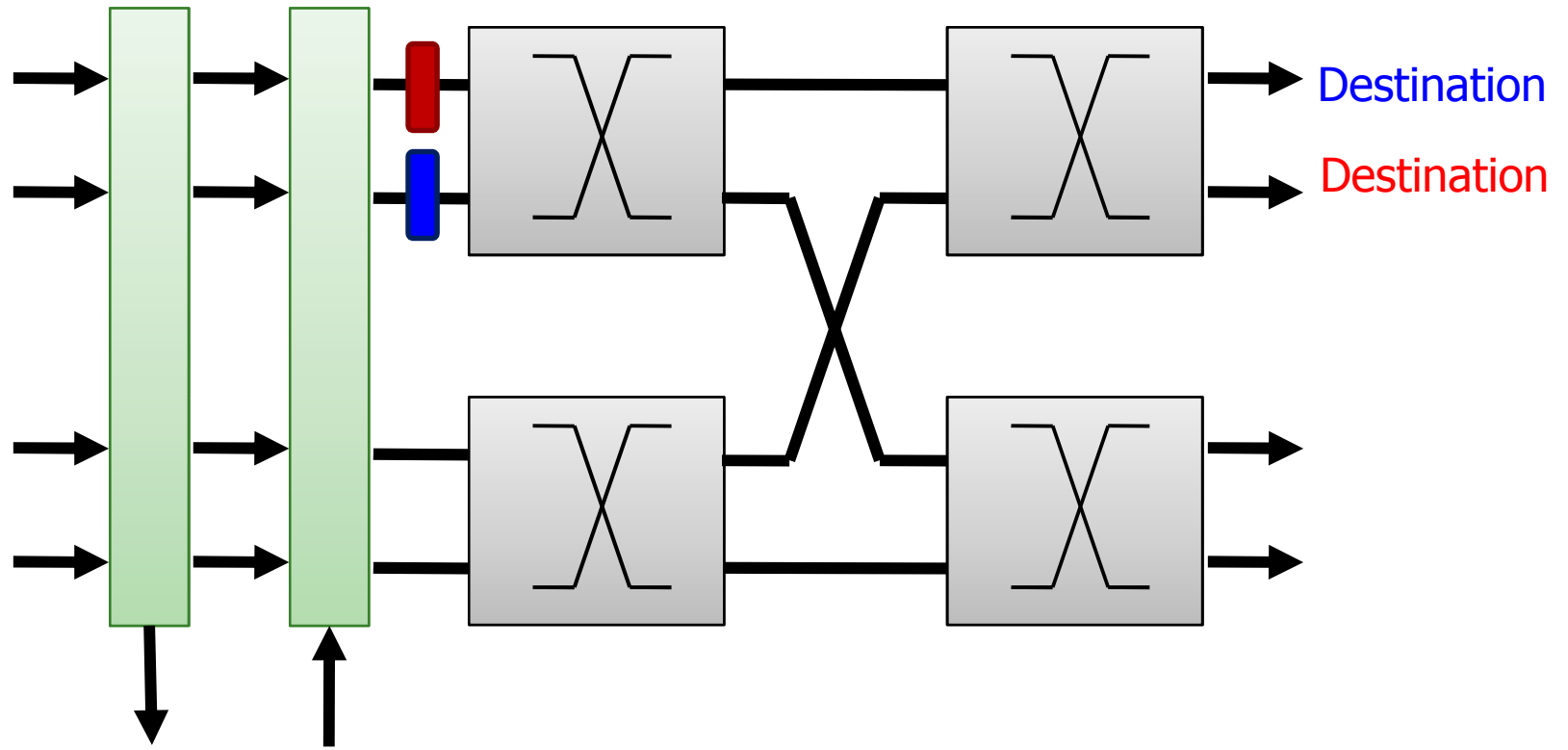

Eject Inject

## Baseline Router

---

<sup>1</sup> Fallin et al., "CHIPPER: A Low-complexity Bufferless Deflection Router", HPCA 2011.

# How to Buffer Deflected Flits

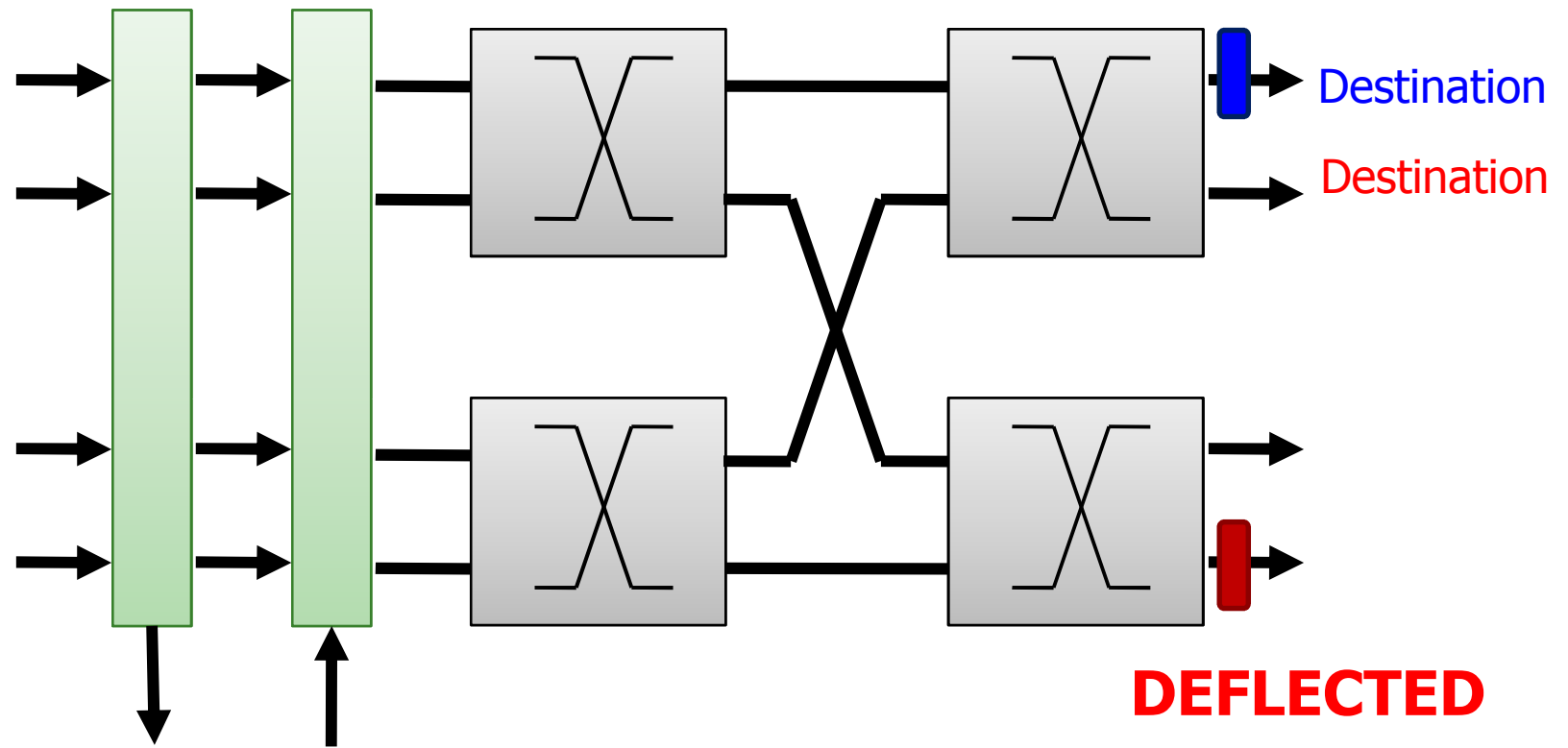

Eject Inject

Baseline Router

<sup>1</sup> Fallin et al., "CHIPPER: A Low-complexity Bufferless Deflection Router", HPCA 2011.

# How to Buffer Deflected Flits

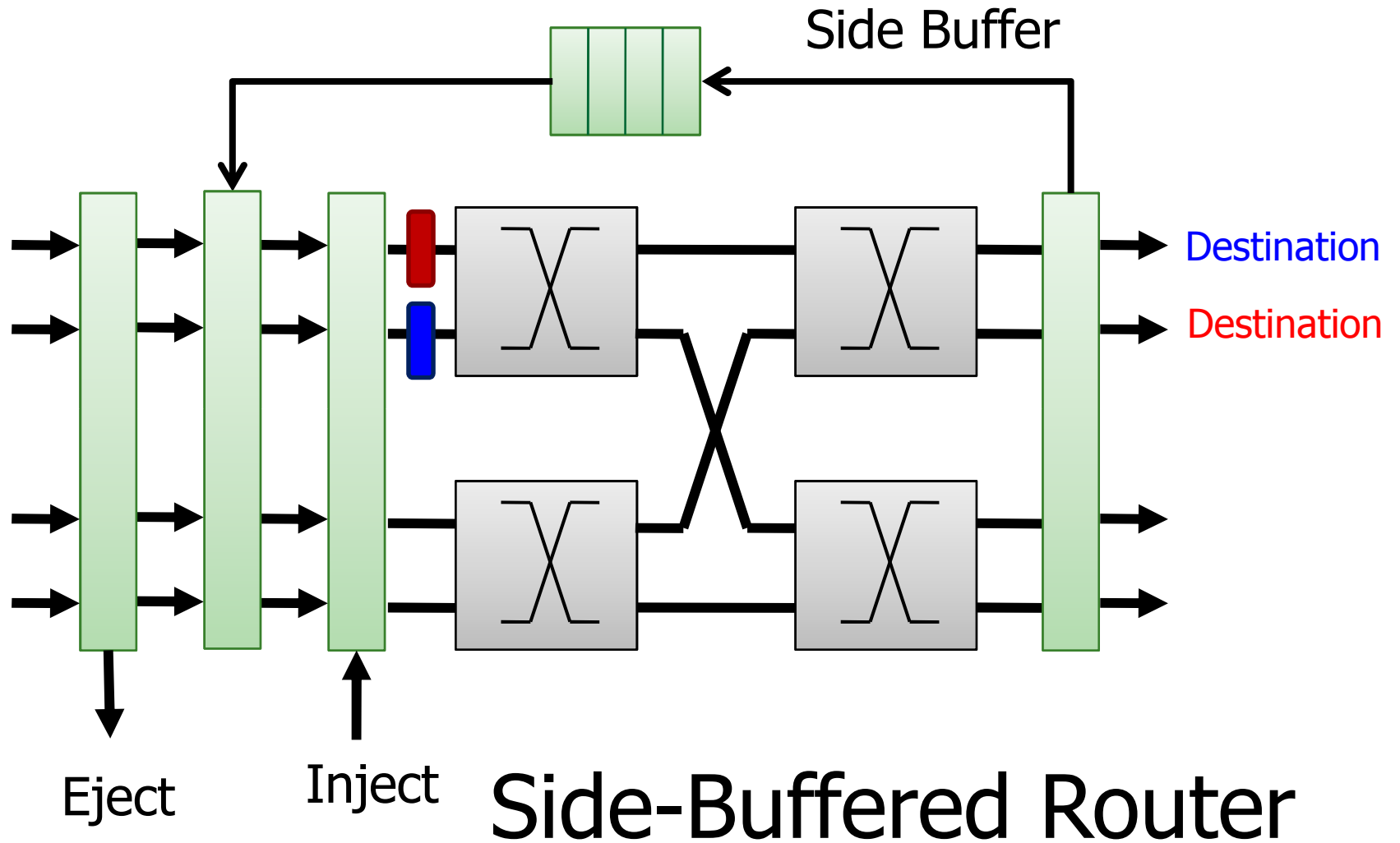

# How to Buffer Deflected Flits

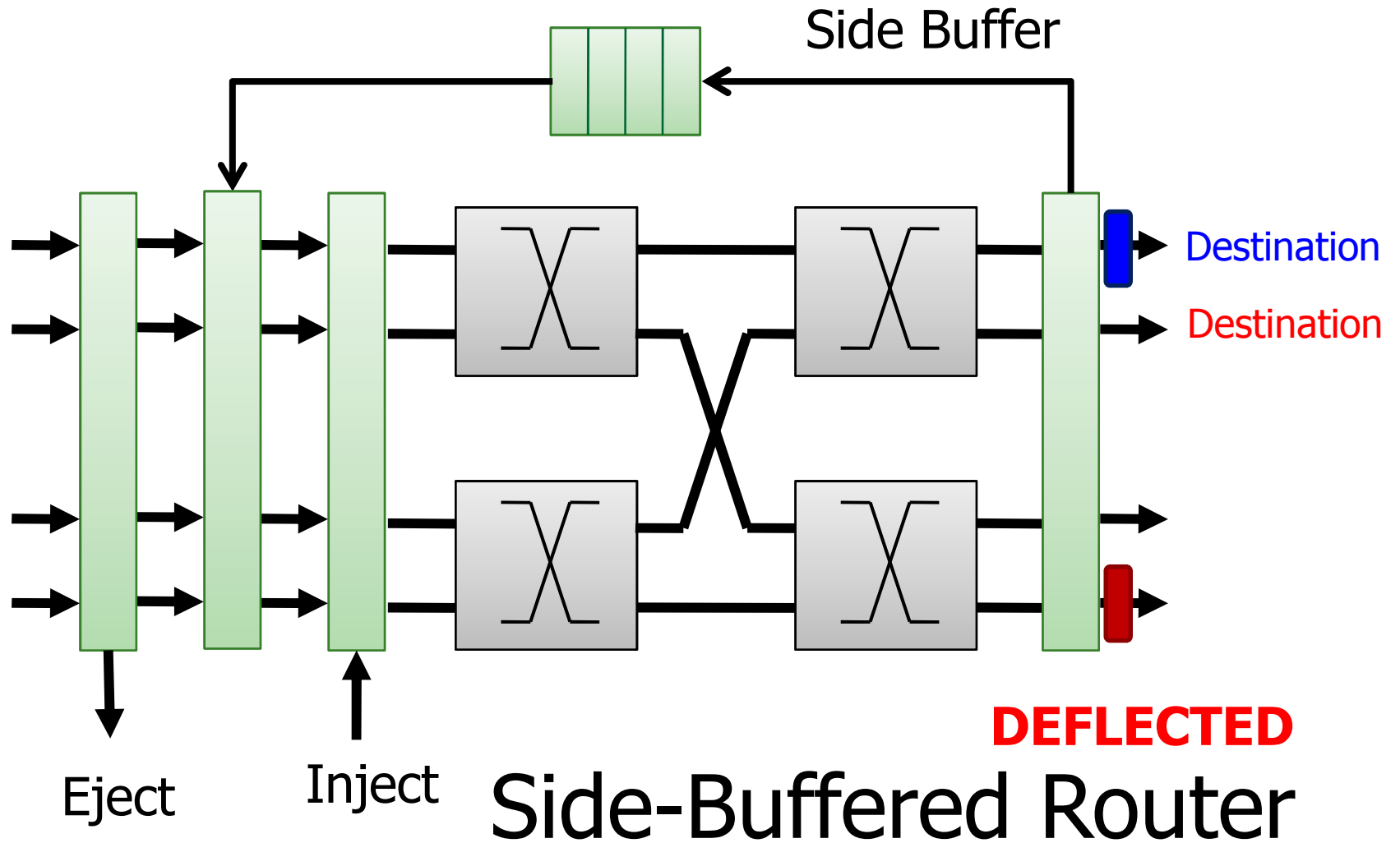

# How to Buffer Deflected Flits

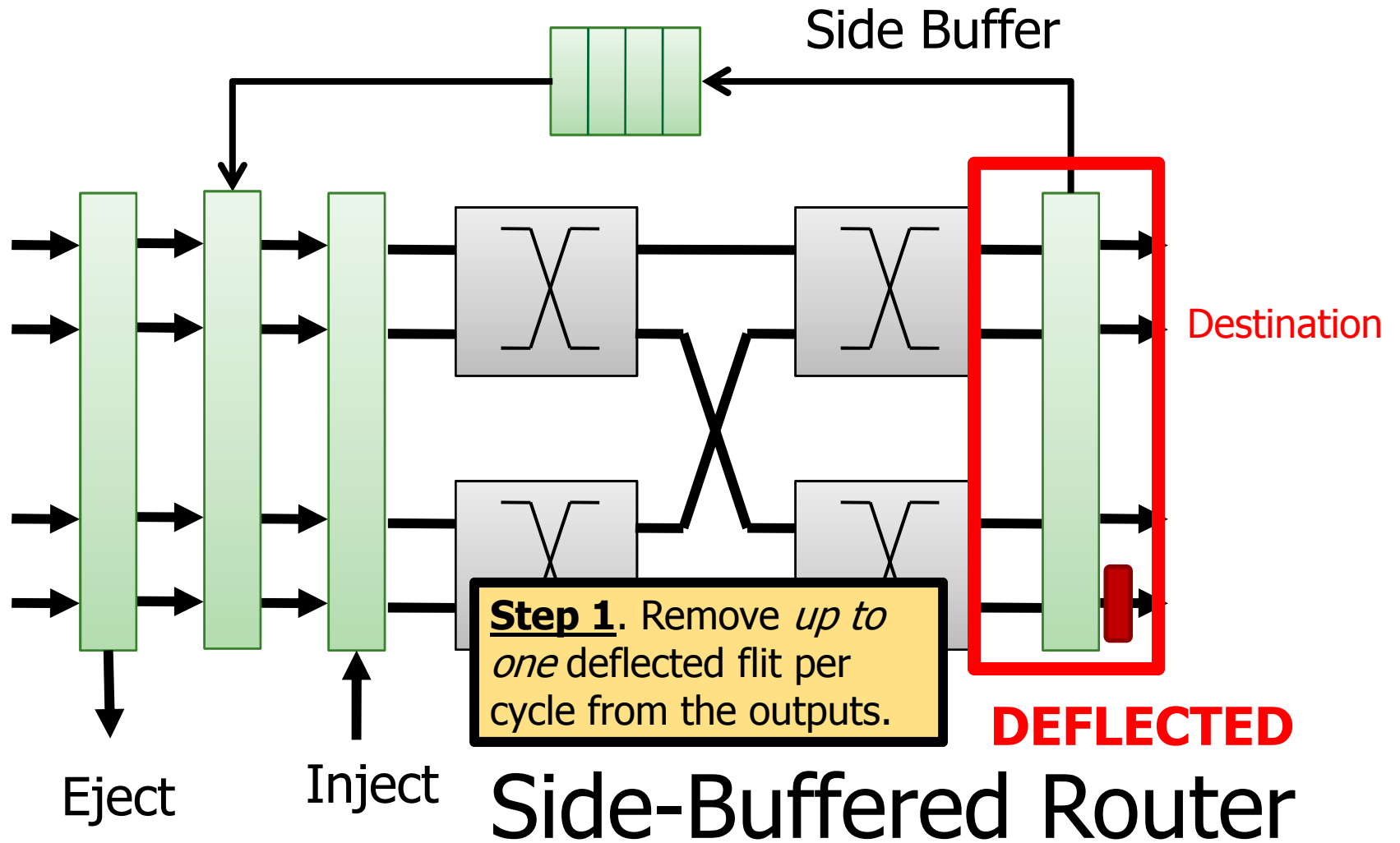

# How to Buffer Deflected Flits

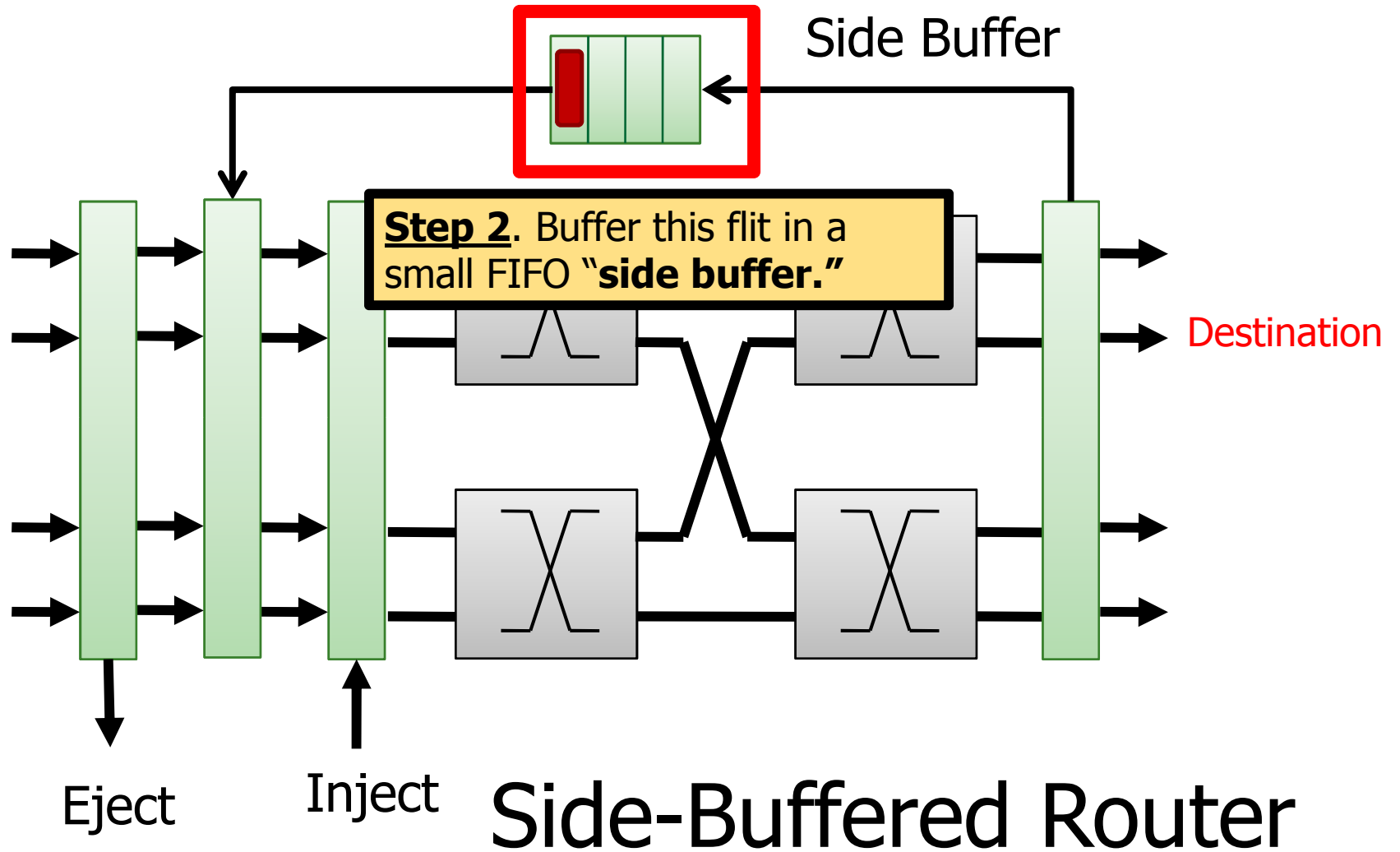

# How to Buffer Deflected Flits

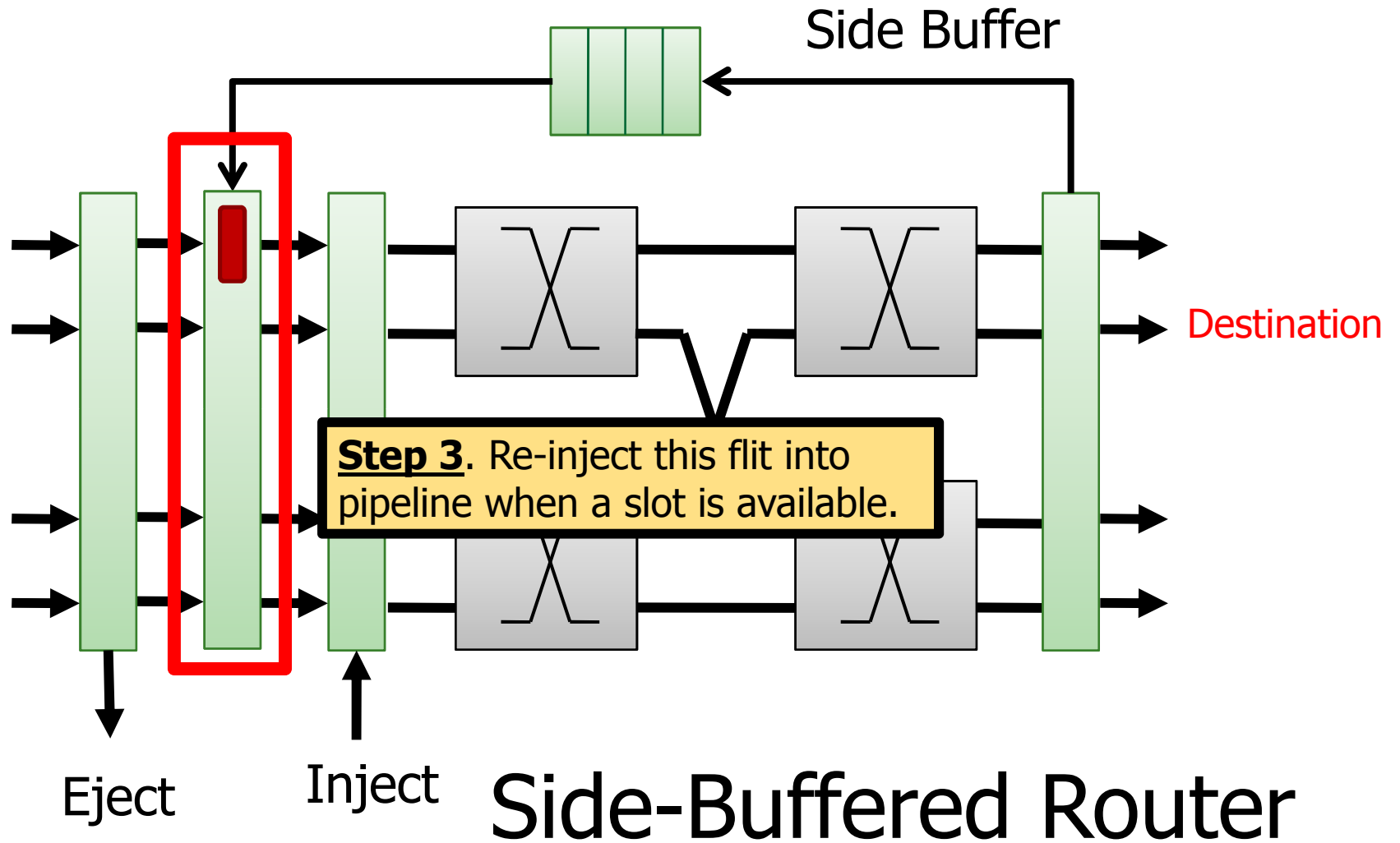

# How to Buffer Deflected Flits

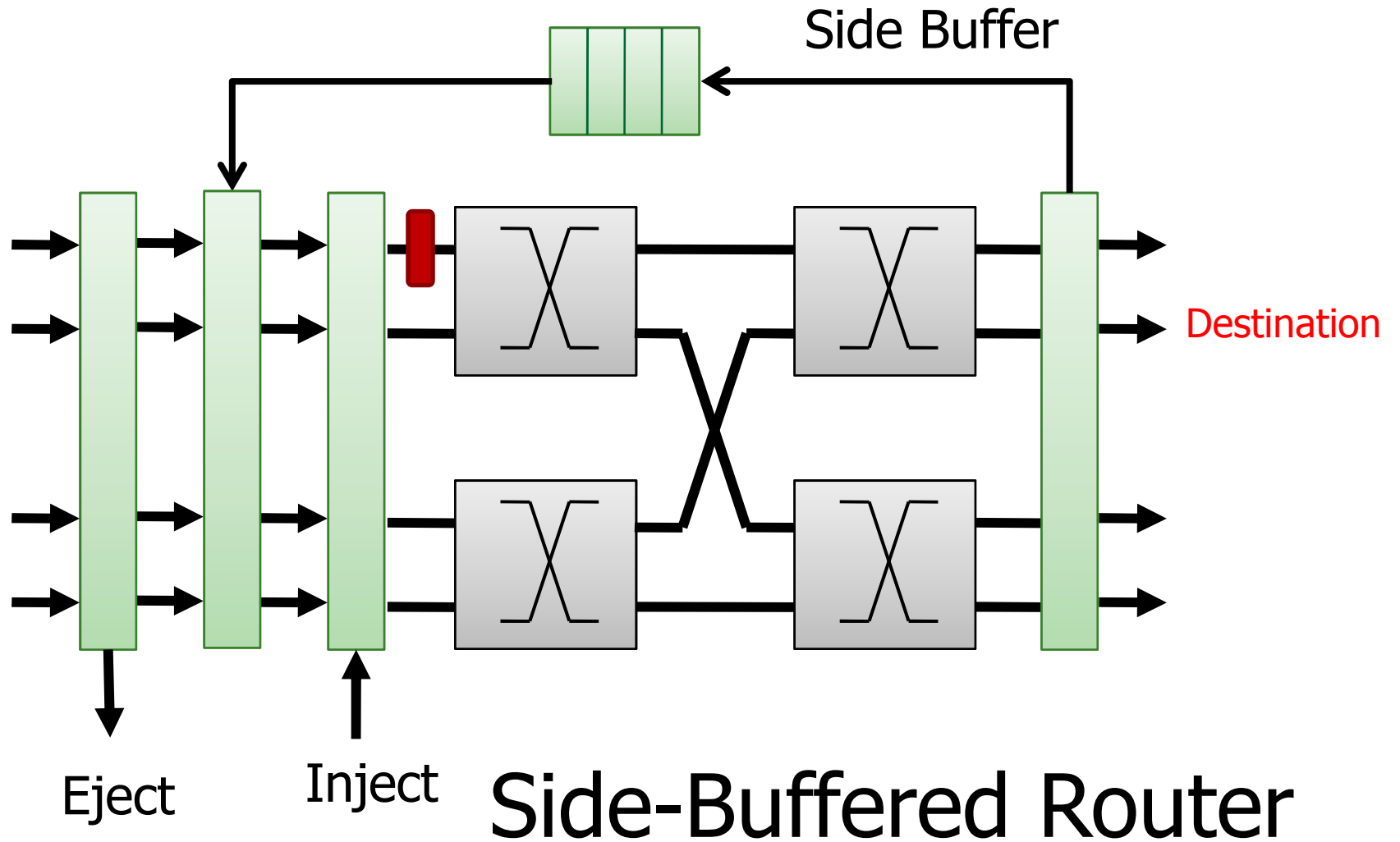



# How to Buffer Deflected Flits

---

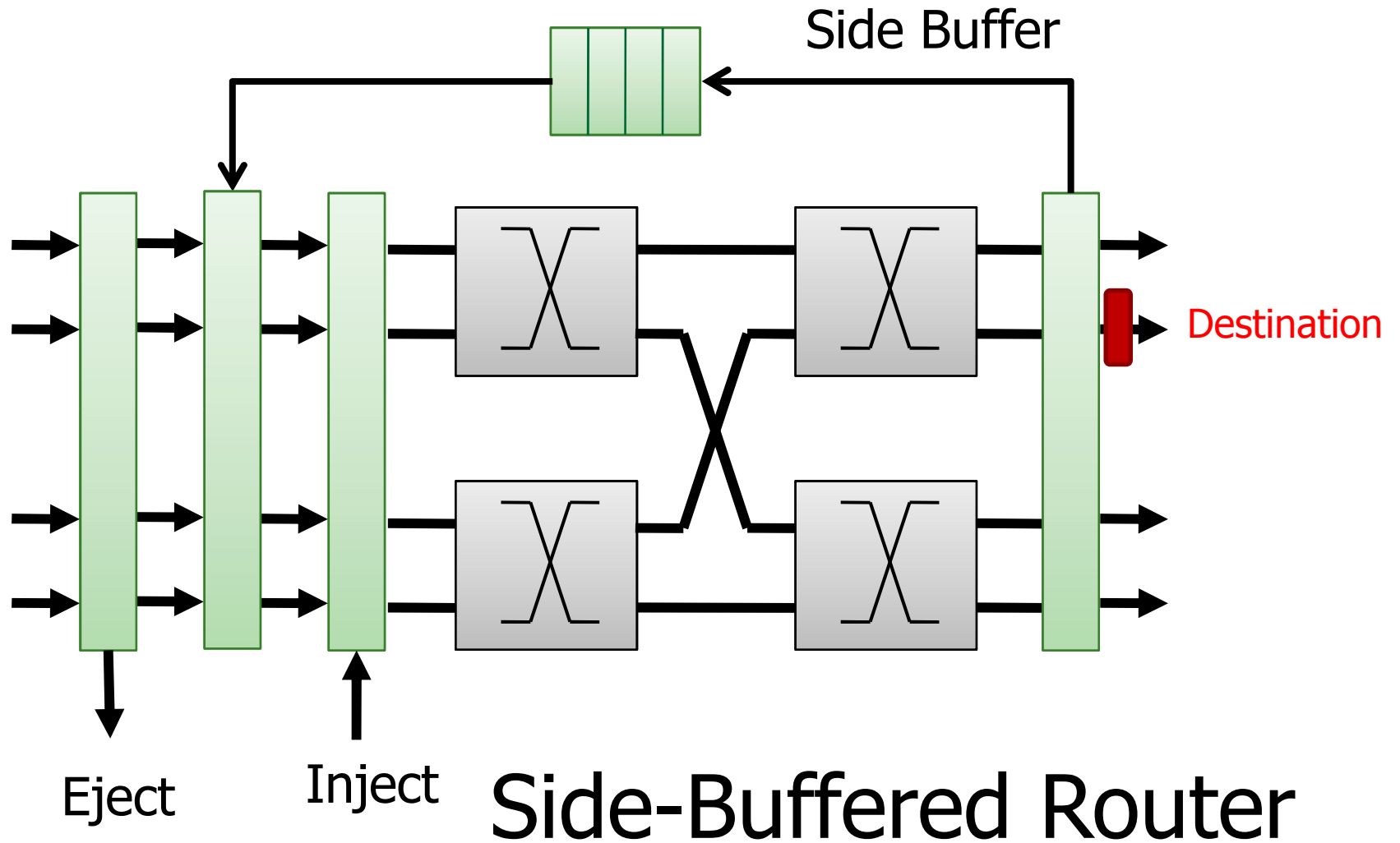

# Why Could A Side Buffer Work Well?

---

- Buffer some flits and deflect other flits at **per-flit level**
  - Relative to **bufferless routers**, **deflection rate reduces** (need not deflect all contending flits)
    - 4-flit buffer reduces deflection rate by **39%**
  - Relative to **buffered routers**, **buffer is more efficiently used** (need not buffer all flits)
    - similar performance with **25%** of buffer space

# Outline: This Talk

---

- **Motivation**
- **Background:** Bufferless Deflection Routing
- **MinBD:** Reducing Deflections
  - Addressing Link Contention
  - Addressing the Ejection Bottleneck
  - Improving Deflection Arbitration
- **Results**
- **Conclusions**

# Addressing the Ejection Bottleneck

---

- **Problem 2:** Flits deflect unnecessarily because only one flit can **eject** per router per cycle
- In 20% of all ejections,  $\geq 2$  flits could have ejected
  - all but one flit must **deflect and try again**
  - these deflected flits cause additional contention
- Ejection width of 2 flits/cycle reduces **deflection rate 21%**
- **Key idea 2:** Reduce deflections due to a single-flit ejection port by allowing **two flits** to eject per cycle

# Addressing the Ejection Bottleneck

---

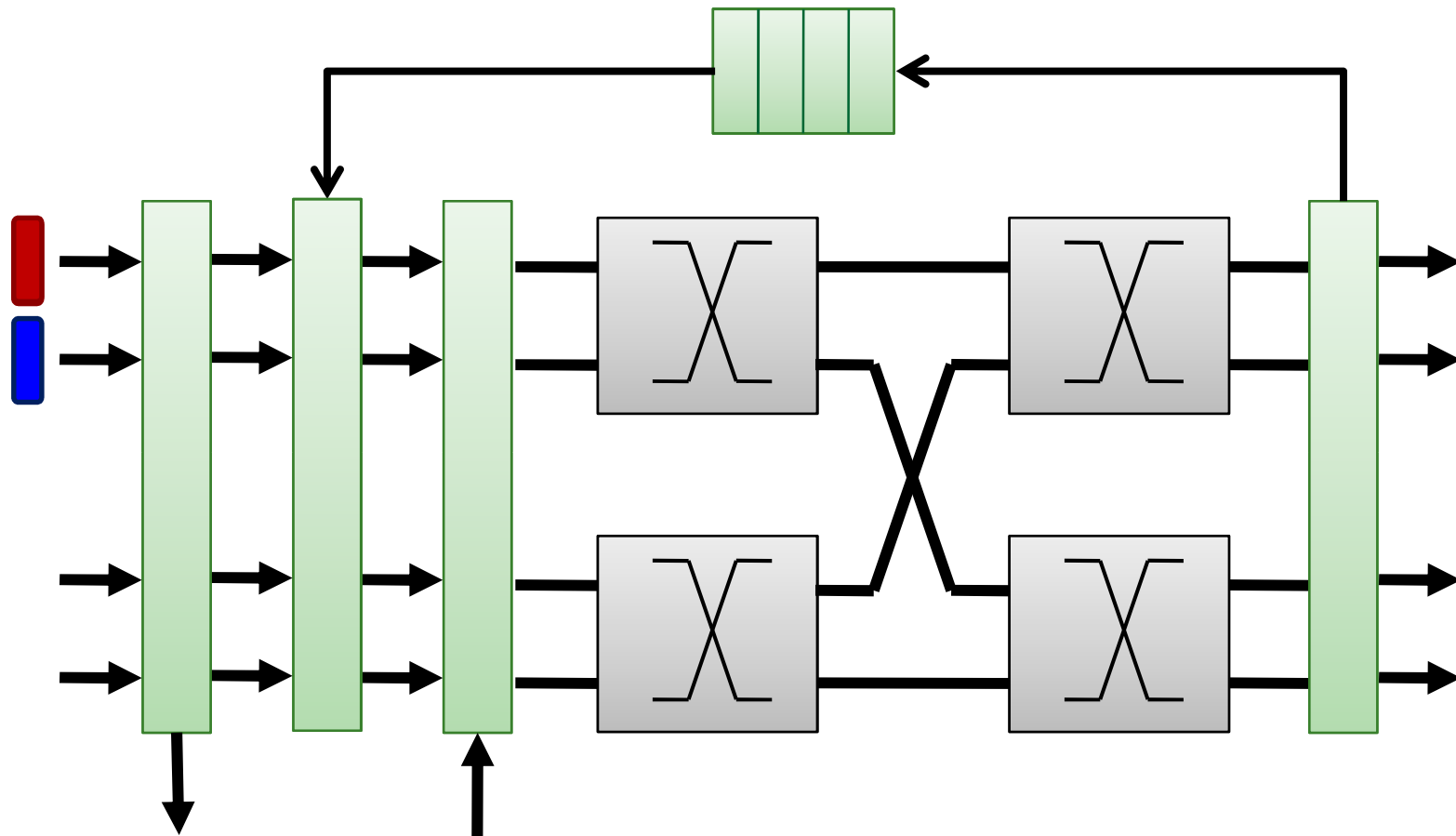

Eject

Inject

## Single-Width Ejection

---

# Addressing the Ejection Bottleneck

---

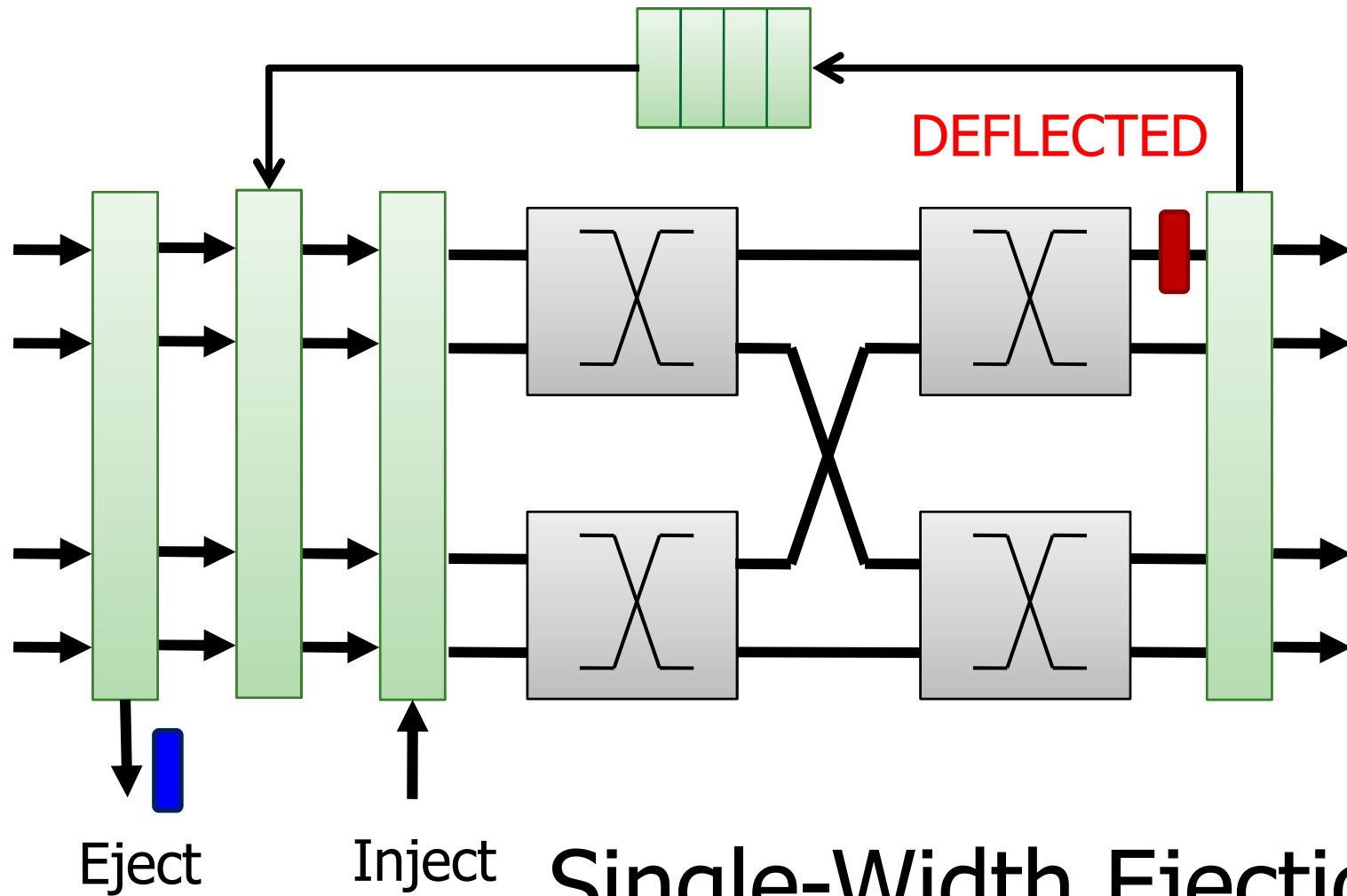

# Addressing the Ejection Bottleneck

---

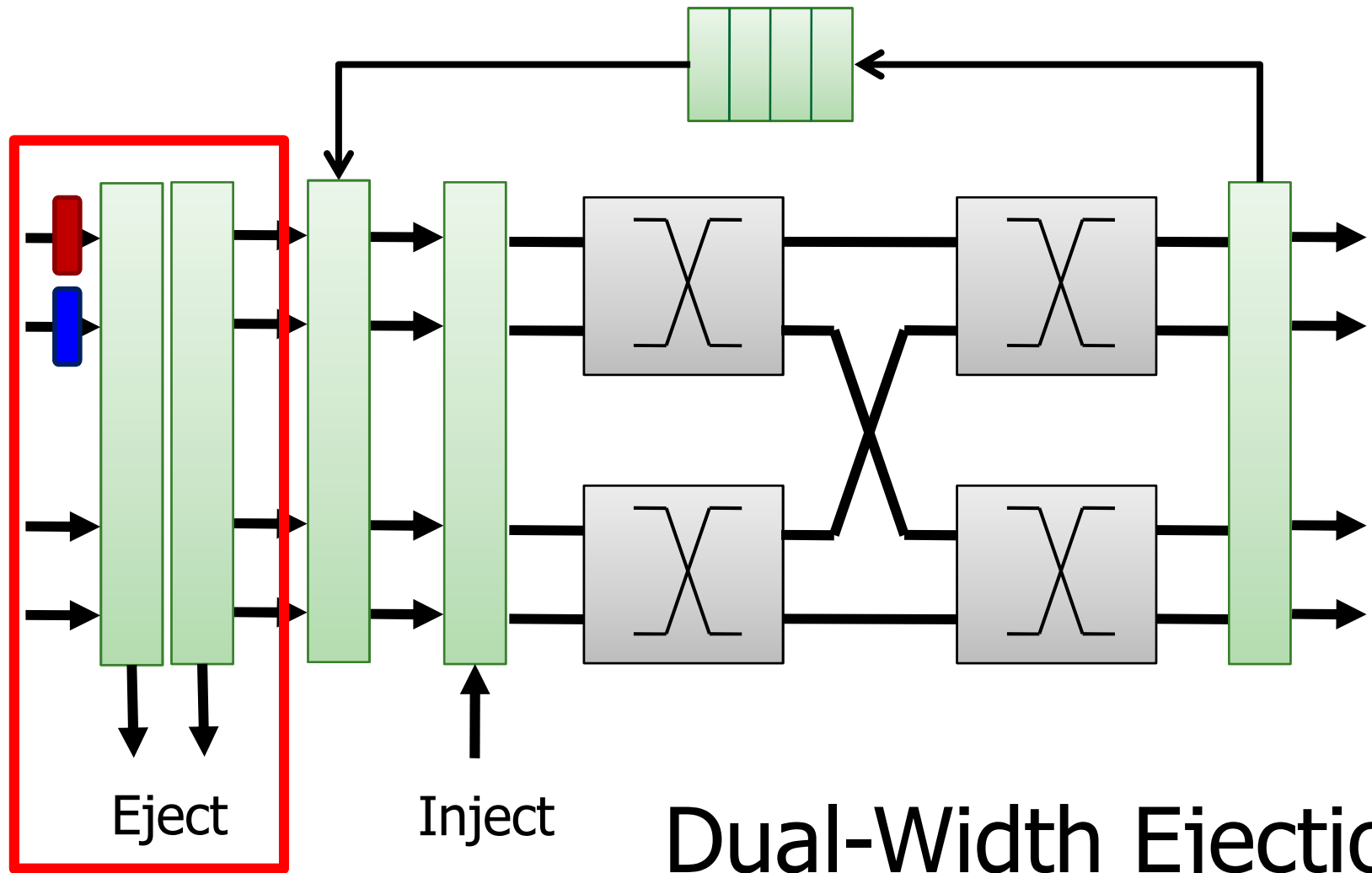

Dual-Width Ejection

# Addressing the Ejection Bottleneck

---

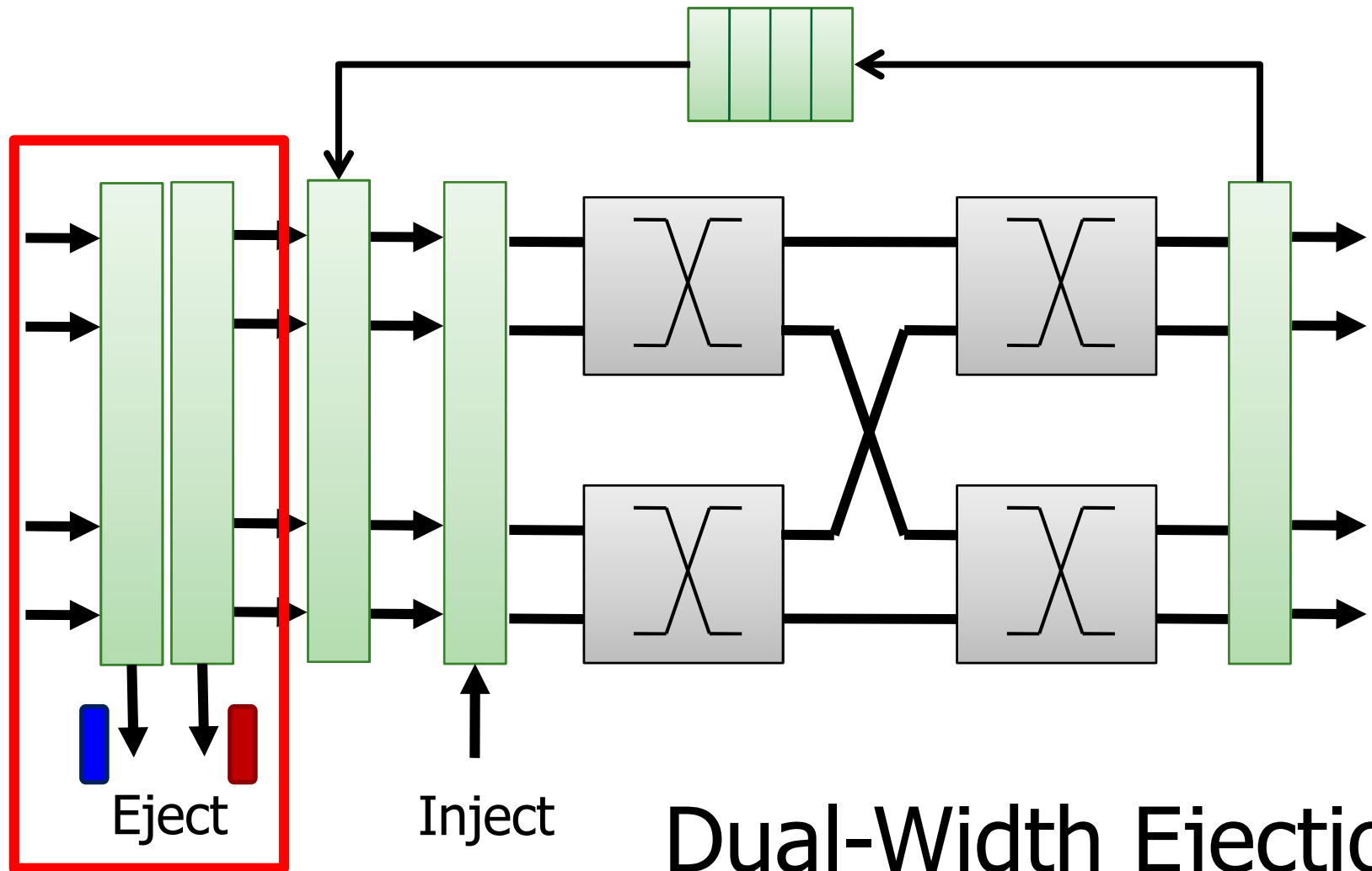

Dual-Width Ejection



# Addressing the Ejection Bottleneck

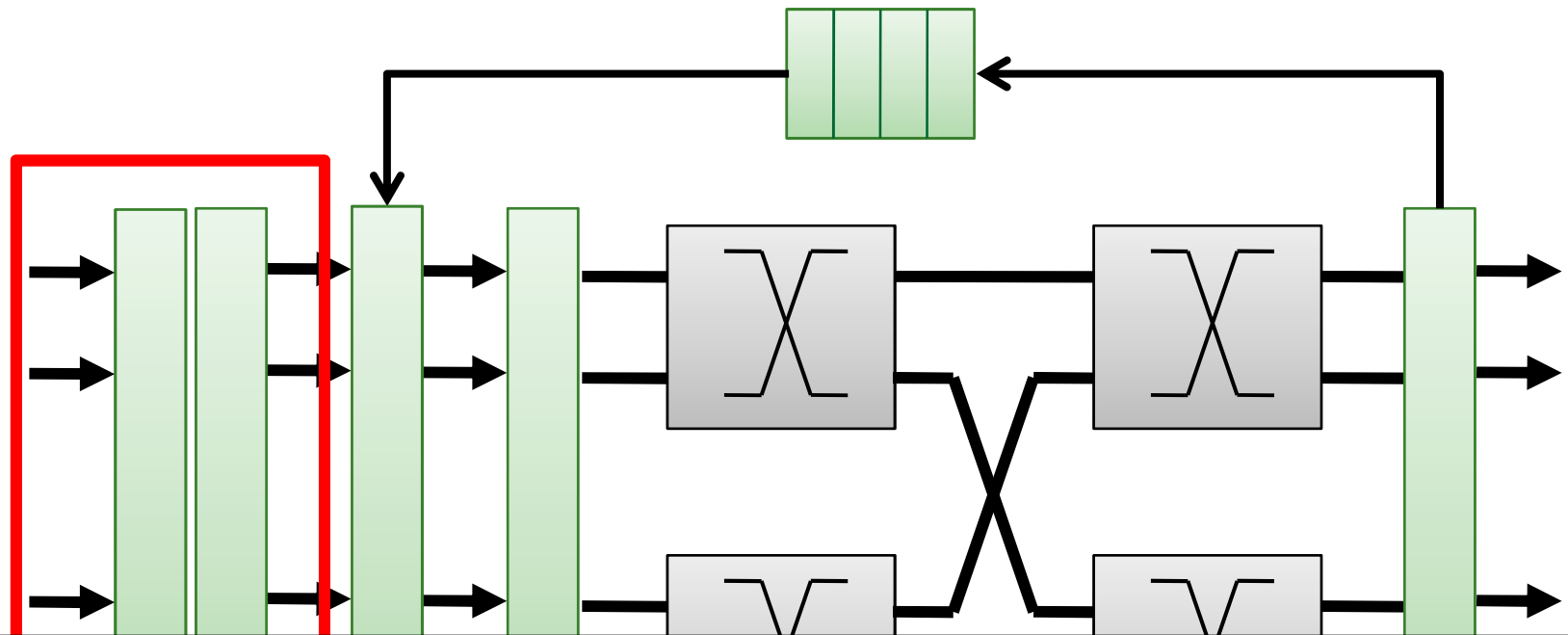

For fair comparison, **baseline routers** have dual-width ejection for perf. (not power/area)

Eject

Inject

Dual-Width Ejection

# Outline: This Talk

---

- **Motivation**
- **Background:** Bufferless Deflection Routing
- **MinBD:** Reducing Deflections
  - Addressing Link Contention
  - Addressing the Ejection Bottleneck
  - Improving Deflection Arbitration
- **Results**
- **Conclusions**

# Improving Deflection Arbitration

---

- **Problem 3:** Deflections occur unnecessarily because fast arbiters must use simple priority schemes
- Age-based priorities (several past works): full priority order gives fewer deflections, but requires **slow arbiters**
- State-of-the-art deflection arbitration (Golden Packet & two-stage permutation network)
  - Prioritize one packet globally (**ensure forward progress**)
  - Arbitrate other flits randomly (**fast critical path**)
- Random common case leads to **uncoordinated arbitration**

# Fast Deflection Routing Implementation

---

- Let's route in a two-input router first:

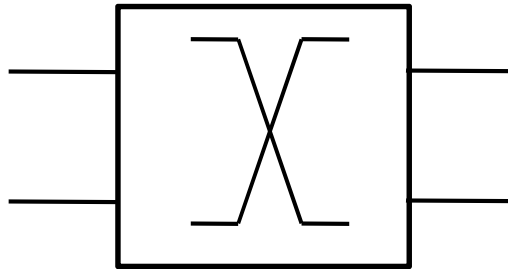

- **Step 1:** pick a “winning” flit (Golden Packet, else random)
- **Step 2:** steer the winning flit to its desired output and deflect other flit

**→ Highest-priority flit always routes to destination**

# Fast Deflection Routing with Four Inputs

---

- Each block makes decisions **independently**
  - **Deflection is a distributed decision**

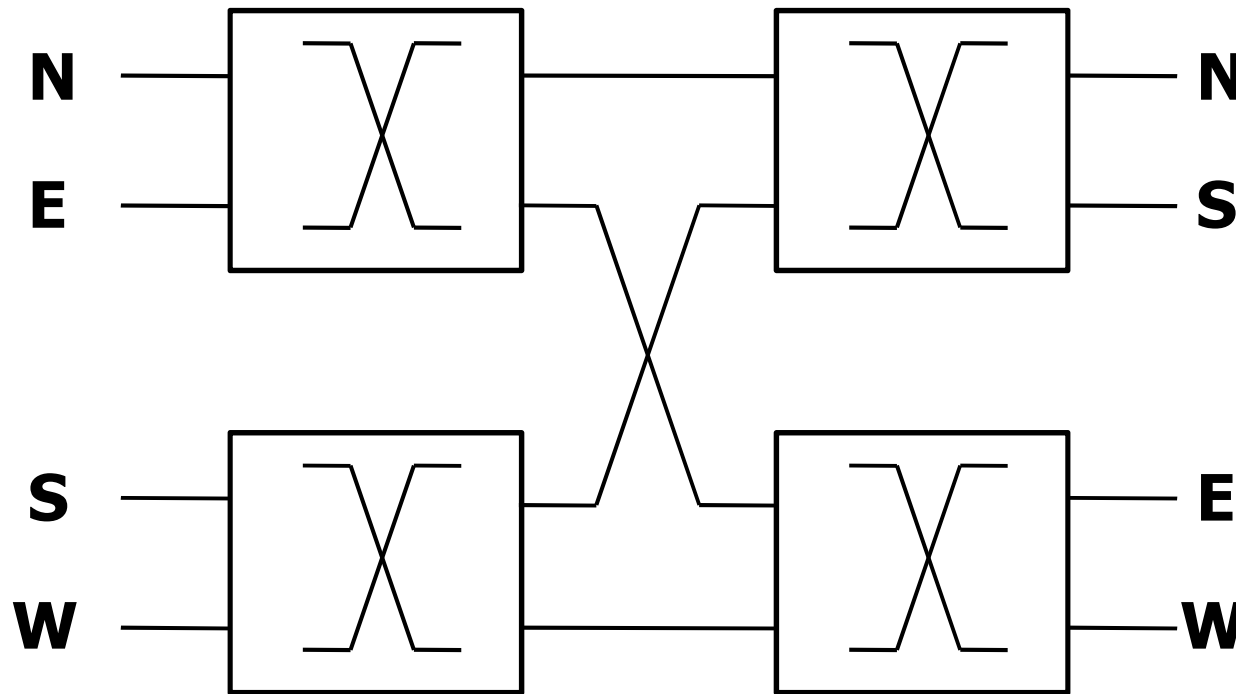

# Unnecessary Deflections in Fast Arbiters

- How does lack of coordination cause unnecessary deflections?
  1. No flit is golden (pseudorandom arbitration)

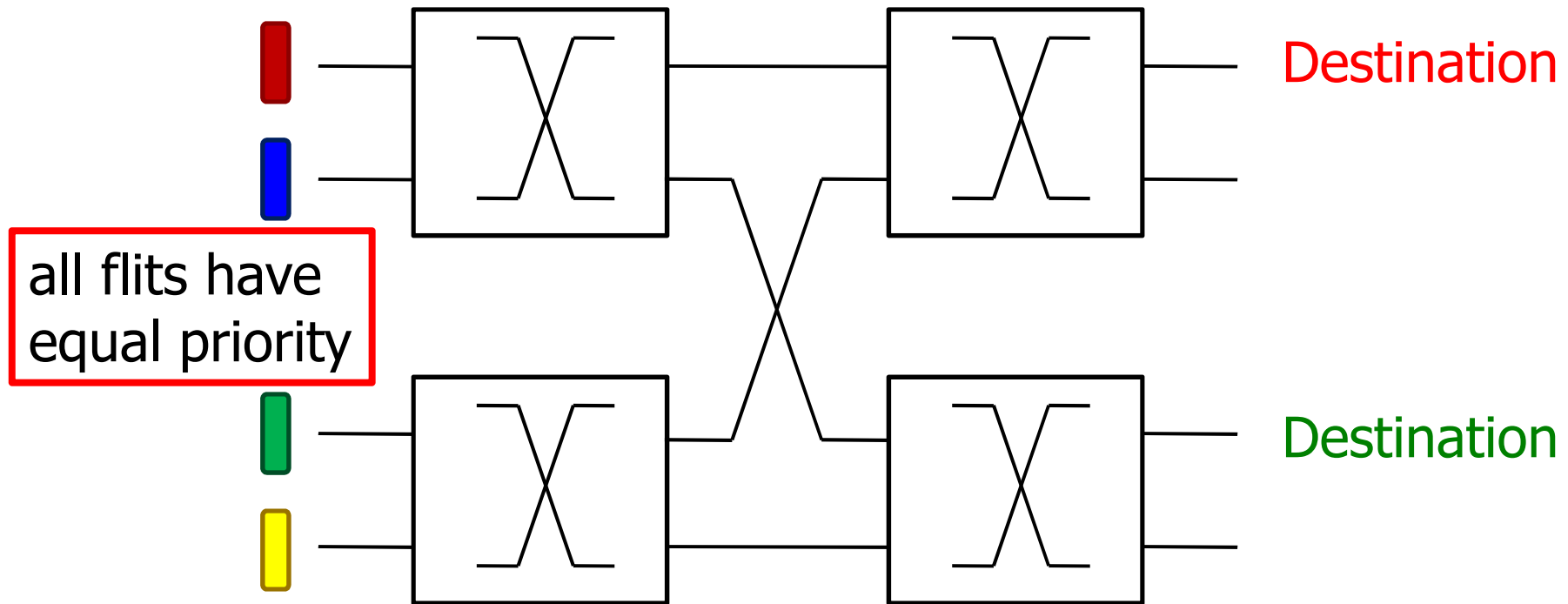

# Unnecessary Deflections in Fast Arbiters

- How does lack of coordination cause unnecessary deflections?
  1. No flit is golden (pseudorandom arbitration)
  2. Red flit wins at first stage
  3. Green flit loses at first stage (must be deflected now)

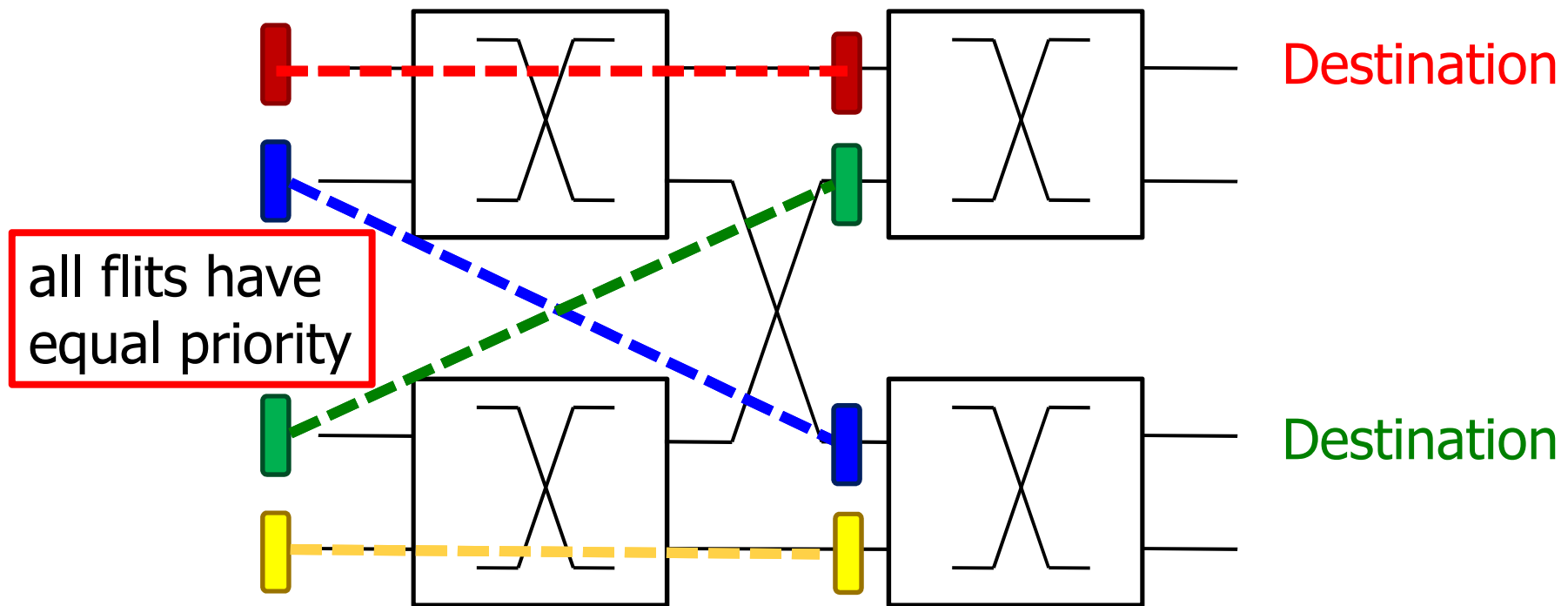

# Unnecessary Deflections in Fast Arbiters

- How does lack of coordination cause unnecessary deflections?
  1. No flit is golden (pseudorandom arbitration)
  2. Red flit wins at first stage
  3. Green flit loses at first stage (must be deflected now)
  4. Red flit loses at second stage; Red and Green are deflected

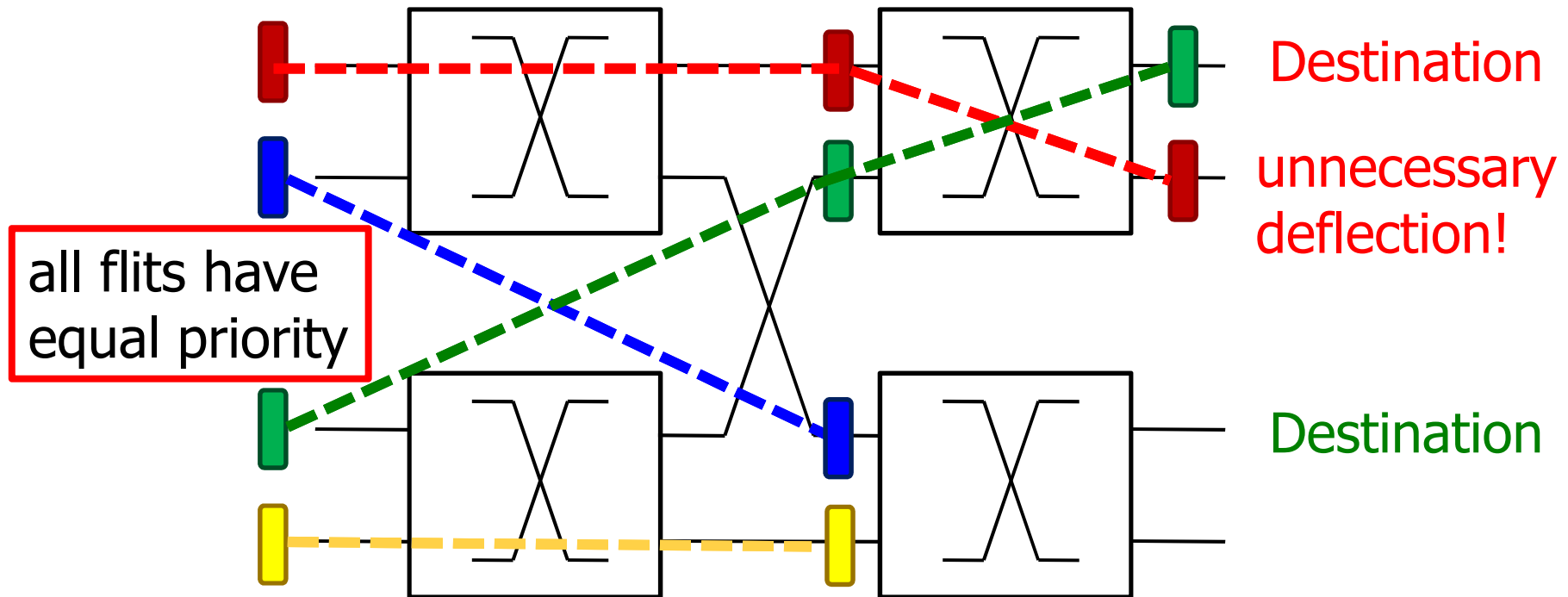



# Improving Deflection Arbitration

---

- **Key idea 3: Add a priority level** and prioritize one flit to ensure at least **one flit is not deflected in each cycle**
  
- **Highest priority:** one **Golden Packet** in network
  - Chosen in static round-robin schedule
  - **Ensures correctness**
  
- **Next-highest priority:** one **silver flit** per router per cycle
  - Chosen pseudo-randomly & local to one router
  - **Enhances performance**

# Adding A Silver Flit

- Randomly picking a silver flit ensures **one flit is not deflected**
  - No flit is golden but **Red** flit is silver

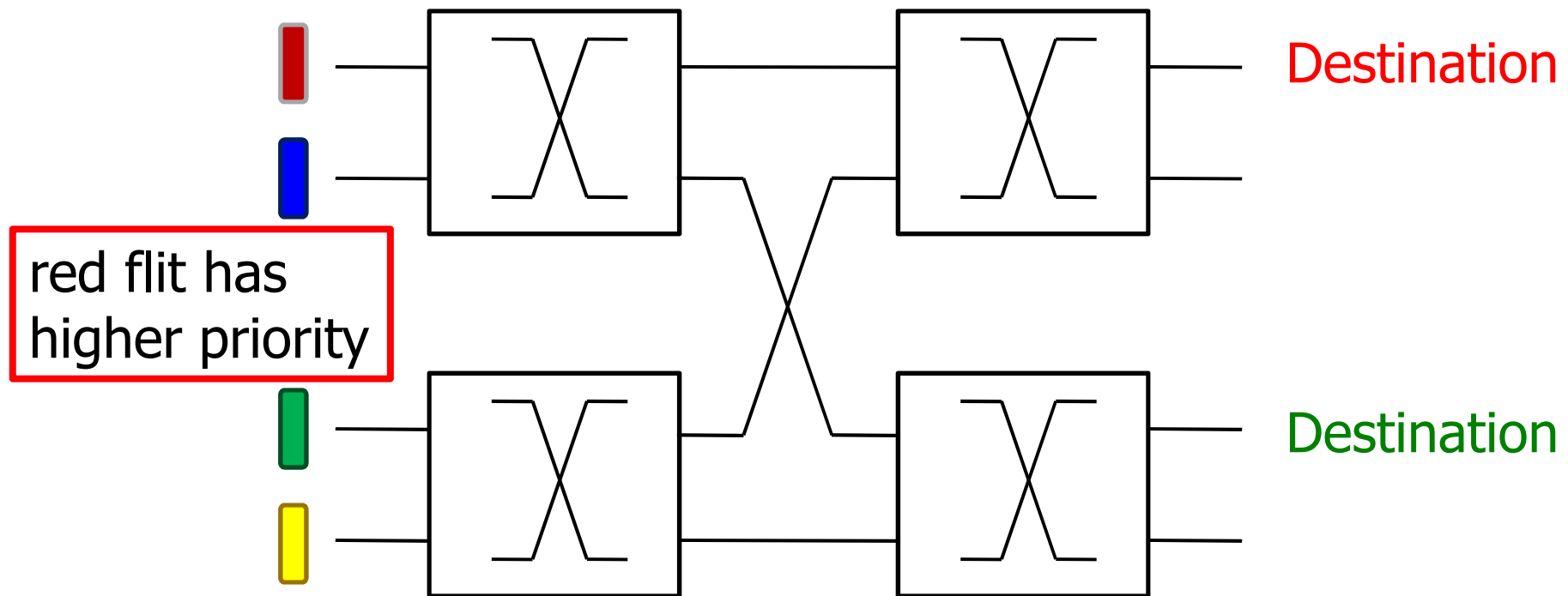

# Adding A Silver Flit

- Randomly picking a silver flit ensures **one flit is not deflected**
  - No flit is golden but **Red** flit is silver
  - Red** flit wins at first stage (silver)
  - Green** flit is deflected at first stage

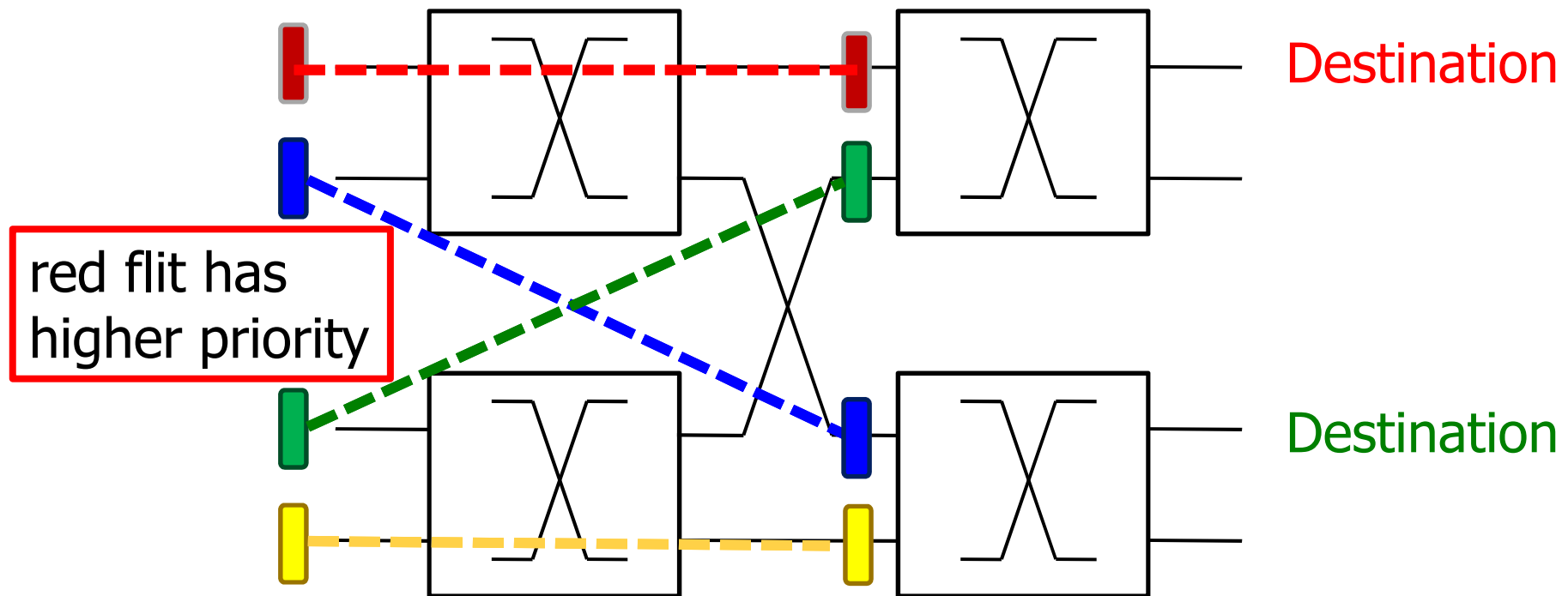

# Adding A Silver Flit

- Randomly picking a silver flit ensures **one flit is not deflected**
  - No flit is golden but Red flit is silver
  - Red flit wins at first stage (silver)
  - Green flit is deflected at first stage
  - Red flit wins at second stage (silver); not deflected

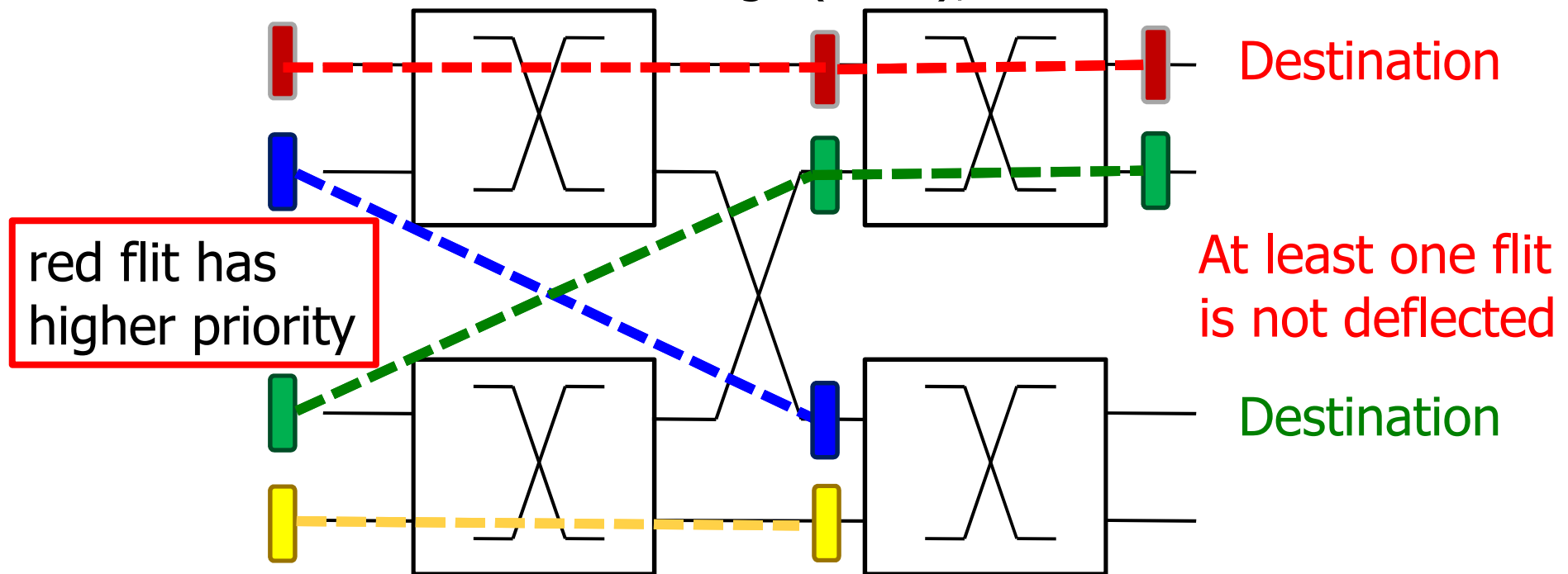

# Minimally-Buffered Deflection Router

---

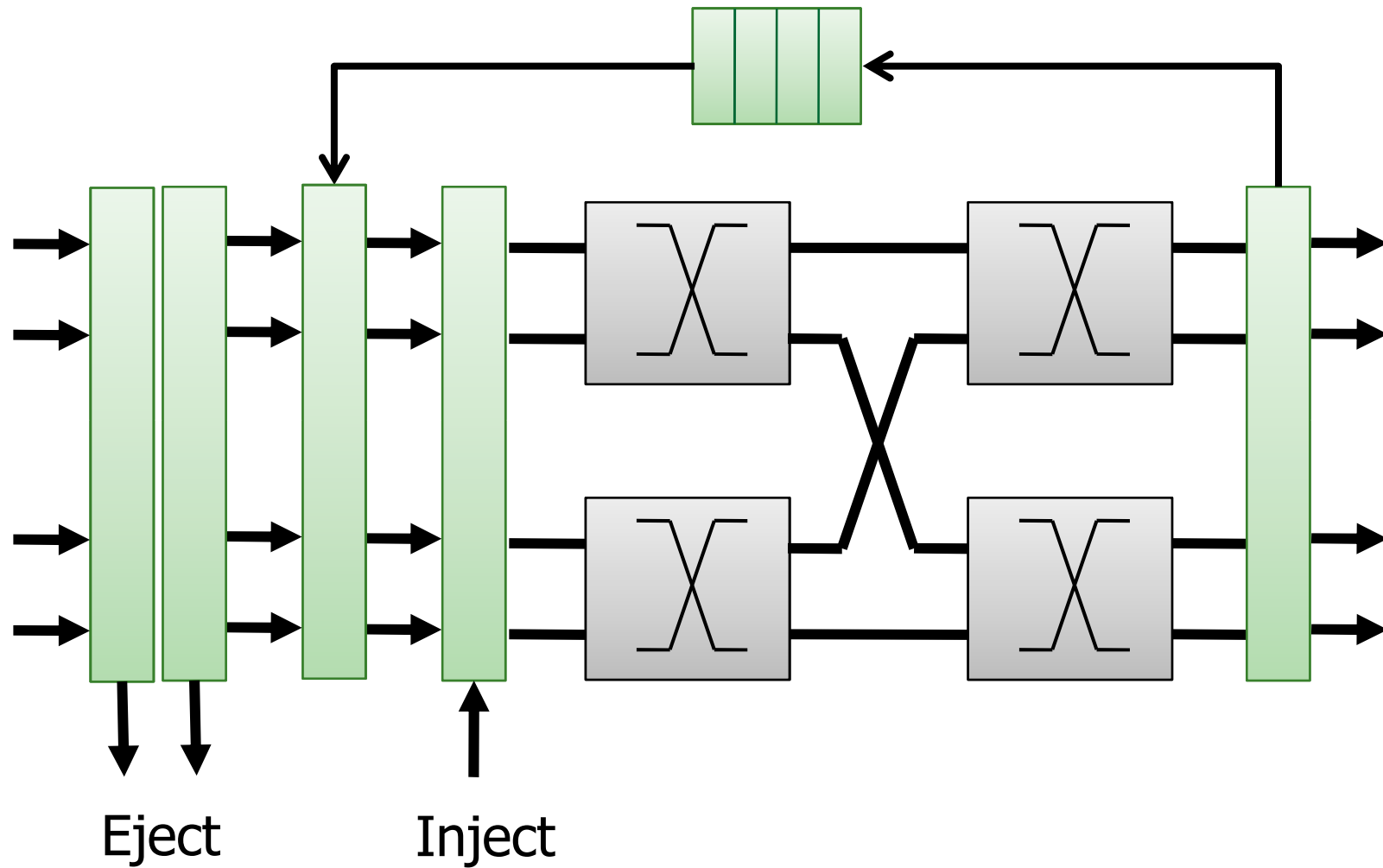

# Minimally-Buffered Deflection Router

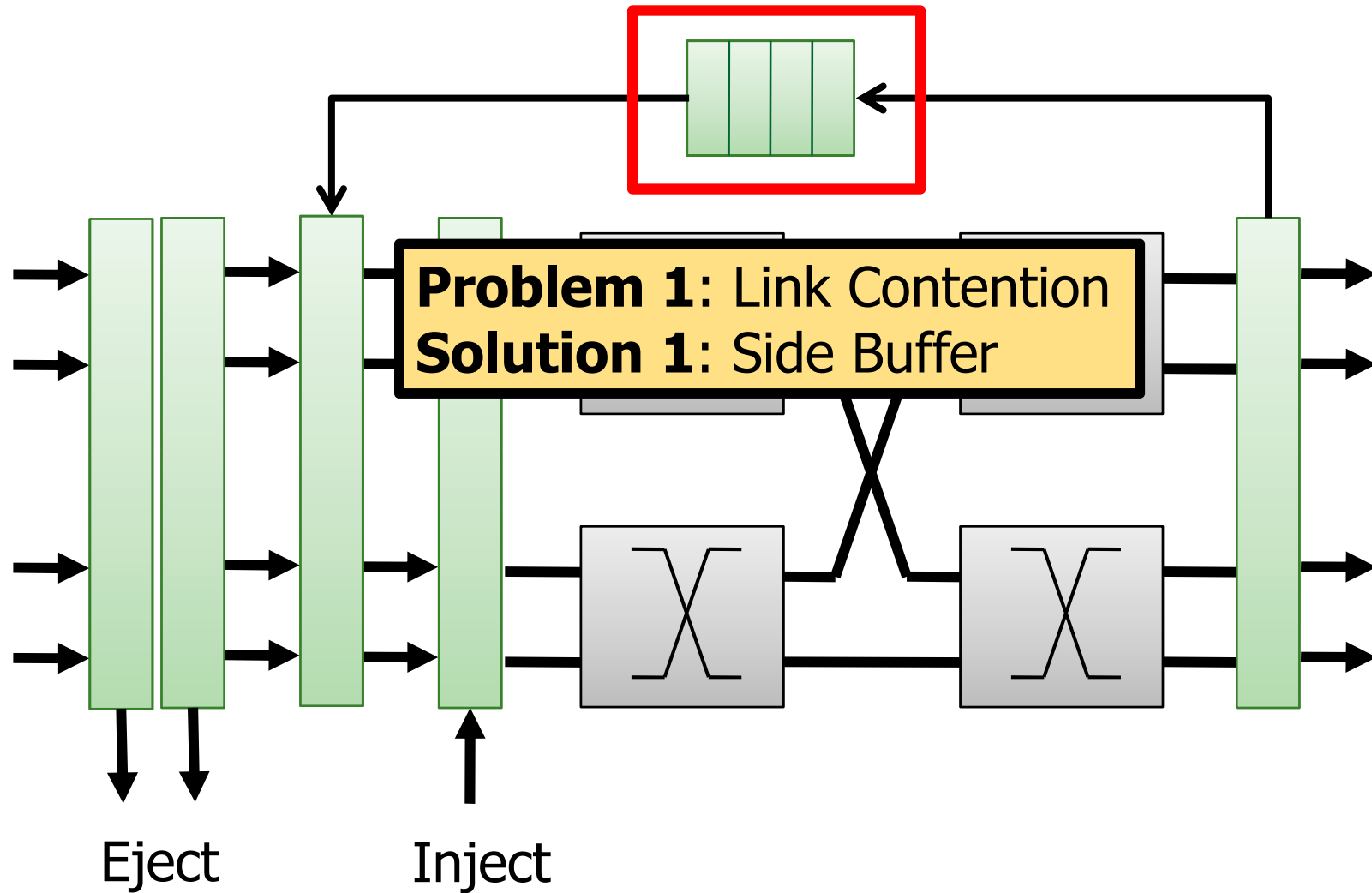

# Minimally-Buffered Deflection Router

---

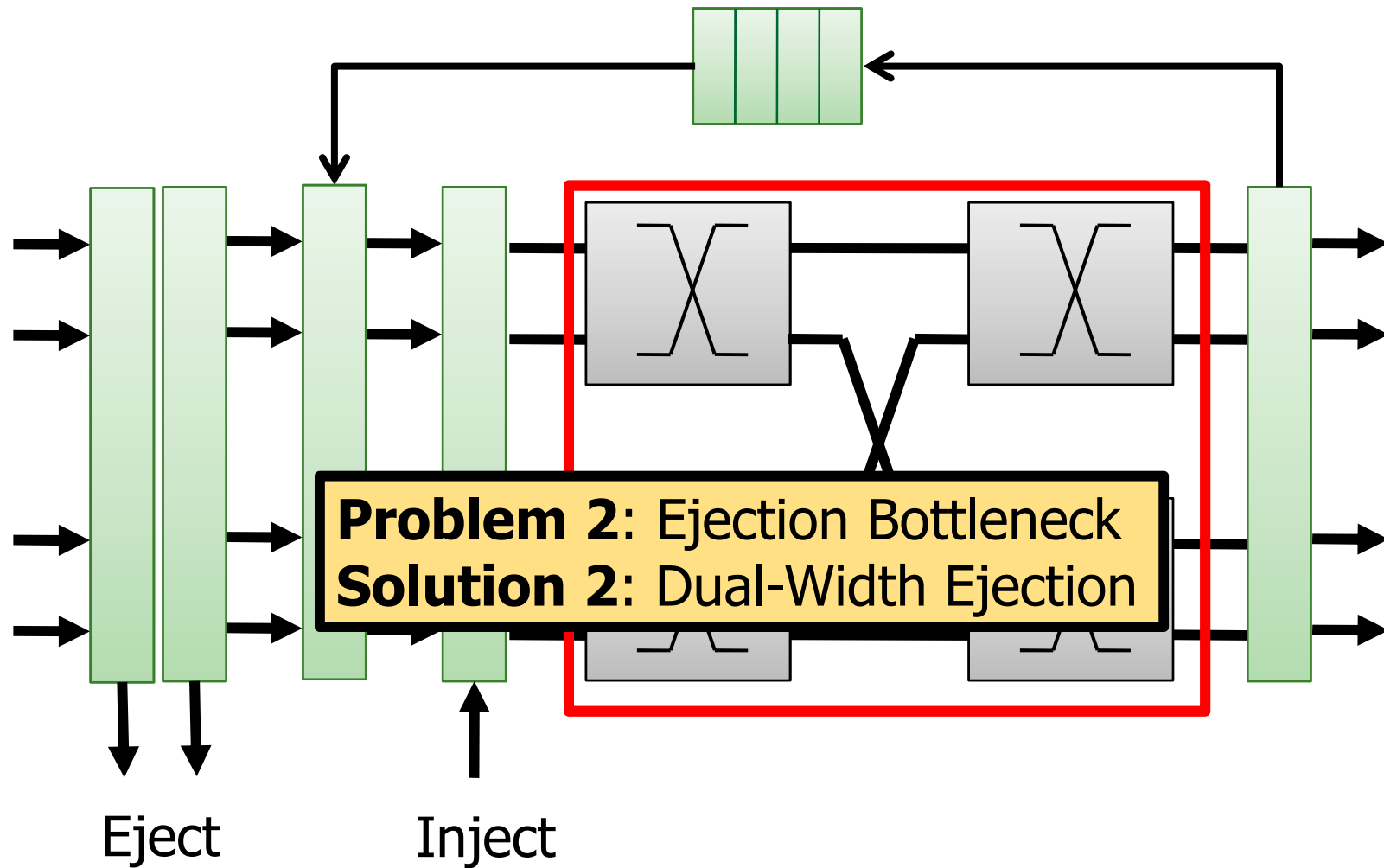

# Minimally-Buffered Deflection Router

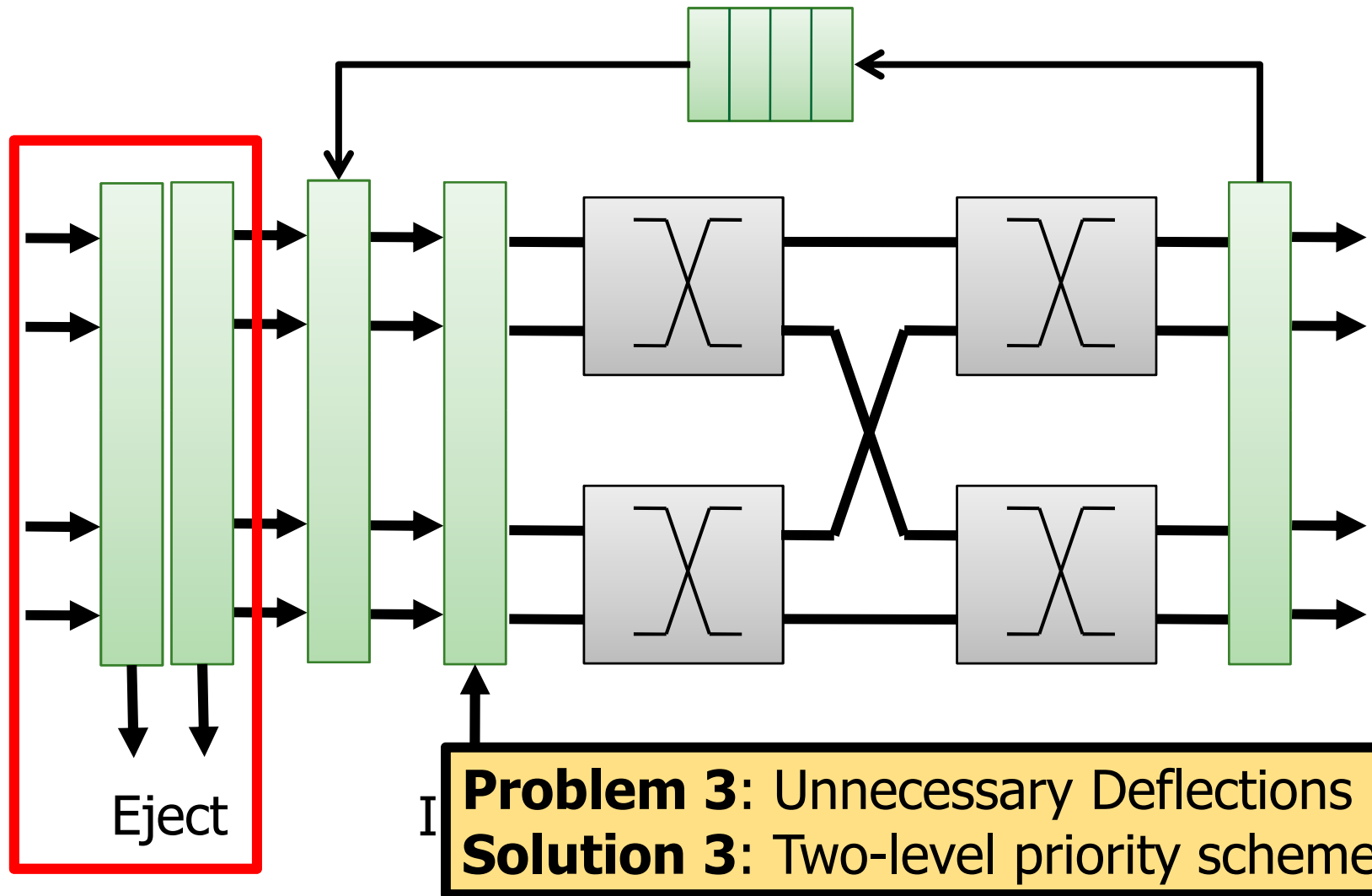



# Minimally-Buffered Deflection Router

---

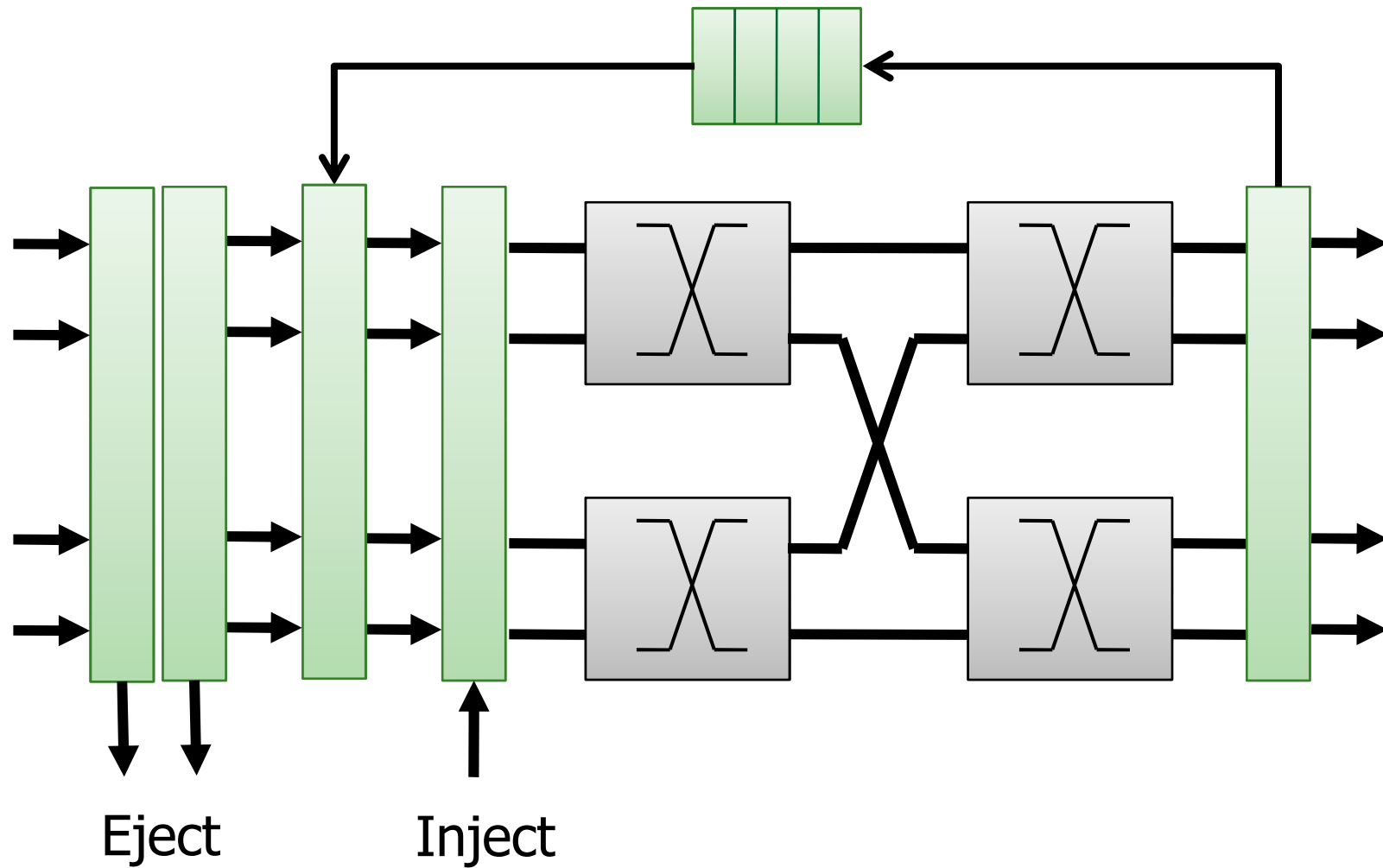

# Outline: This Talk

---

- **Motivation**
- **Background:** Bufferless Deflection Routing
- **MinBD:** Reducing Deflections
  - Addressing Link Contention
  - Addressing the Ejection Bottleneck
  - Improving Deflection Arbitration

# Outline: This Talk

---

- **Motivation**
- **Background:** Bufferless Deflection Routing
- **MinBD:** Reducing Deflections
  - Addressing Link Contention
  - Addressing the Ejection Bottleneck
  - Improving Deflection Arbitration
- **Results**
- **Conclusions**

# Methodology: Simulated System

---

## ■ **Chip Multiprocessor Simulation**

- **64-core** and **16-core** models
- **Closed-loop** core/cache/NoC cycle-level model
- Directory cache coherence protocol (SGI Origin-based)
- 64KB L1, perfect L2 (stresses interconnect), XOR-mapping
- Performance metric: **Weighted Speedup**  
(similar conclusions from network-level latency)
- Workloads: multiprogrammed SPEC CPU2006
  - 75 randomly-chosen workloads
  - Binned into network-load categories by average injection rate

# Methodology: Routers and Network

---

- **Input-buffered** virtual-channel router
    - 8 VCs, 8 flits/VC [[Buffered\(8,8\)](#)]: large buffered router
    - 4 VCs, 4 flits/VC [[Buffered\(4,4\)](#)]: typical buffered router
    - 4 VCs, 1 flit/VC [[Buffered\(4,1\)](#)]: smallest deadlock-free router
    - All power-of-2 buffer sizes up to (8, 8) for perf/power sweep
  - **Bufferless deflection** router: **CHIPPER**<sup>1</sup>
  - **Bufferless-buffered hybrid** router: **AFC**<sup>2</sup>
    - Has input buffers and deflection routing logic
    - Performs coarse-grained (multi-cycle) mode switching
  - **Common parameters**
    - 2-cycle router latency, 1-cycle link latency
    - 2D-mesh topology (16-node: 4x4; 64-node: 8x8)
    - Dual ejection assumed for baseline routers (for perf. only)
- 

<sup>1</sup>Fallin et al., "CHIPPER: A Low-complexity Bufferless Deflection Router", HPCA 2011.

<sup>2</sup>Jafri et al., "Adaptive Flow Control for Robust Performance and Energy", MICRO 2010.

# Methodology: Power, Die Area, Crit. Path

---

## ■ **Hardware modeling**

- **Verilog models** for CHIPPER, MinBD, buffered control logic
  - Synthesized with commercial 65nm library
- **ORION 2.0** for datapath: crossbar, muxes, buffers and links

## ■ **Power**

- Static and dynamic power from hardware models
- Based on event counts in cycle-accurate simulations
- Broken down into buffer, link, other

# Reduced Deflections & Improved Perf.

1. All mechanisms individually reduce deflections

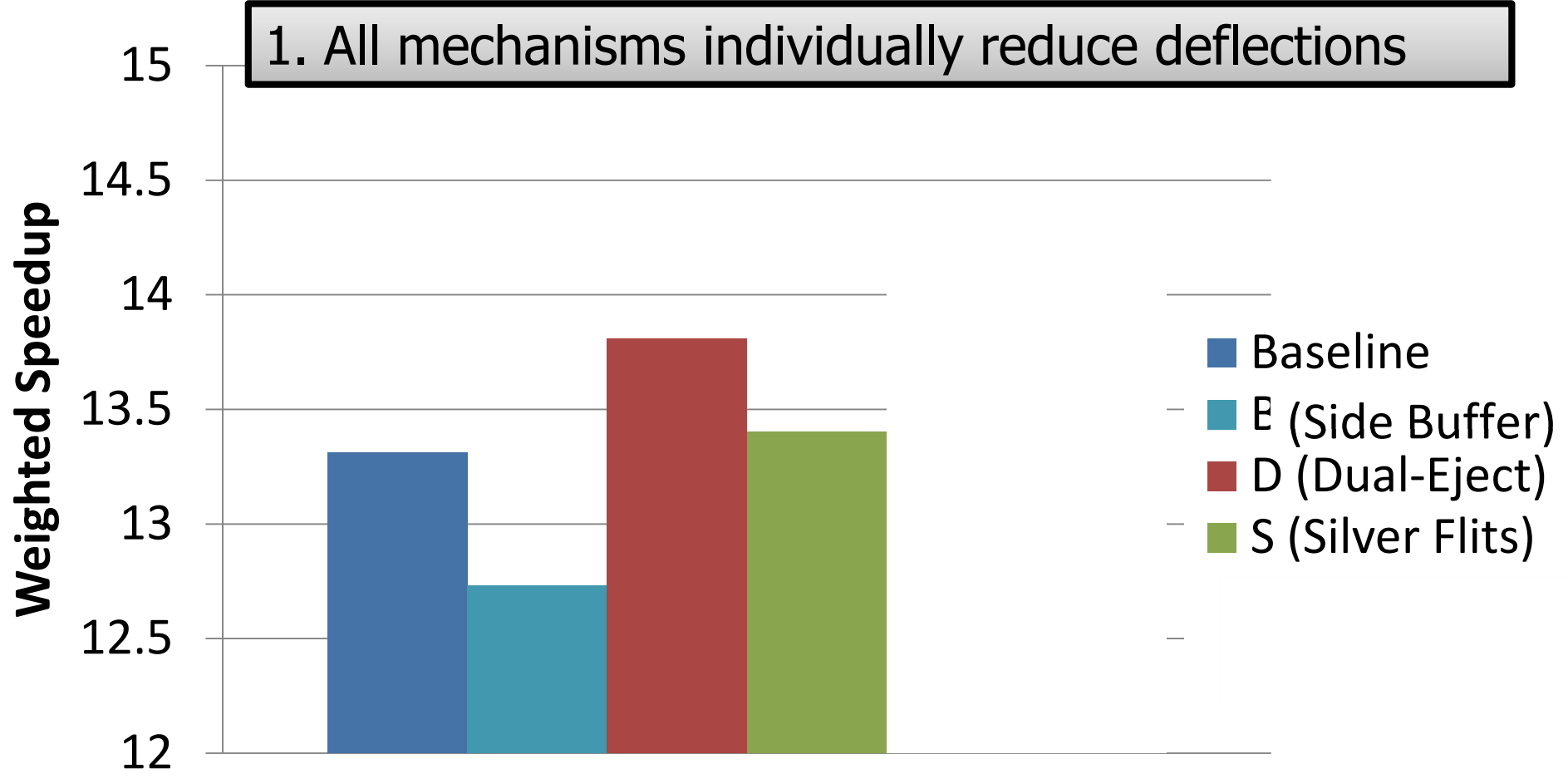

<b>Deflection Rate</b>	<b>28%</b>	<b>17%</b>	<b>22%</b>	<b>27%</b>		
------------------------	------------	------------	------------	------------	--	--

# Reduced Deflections & Improved Perf.

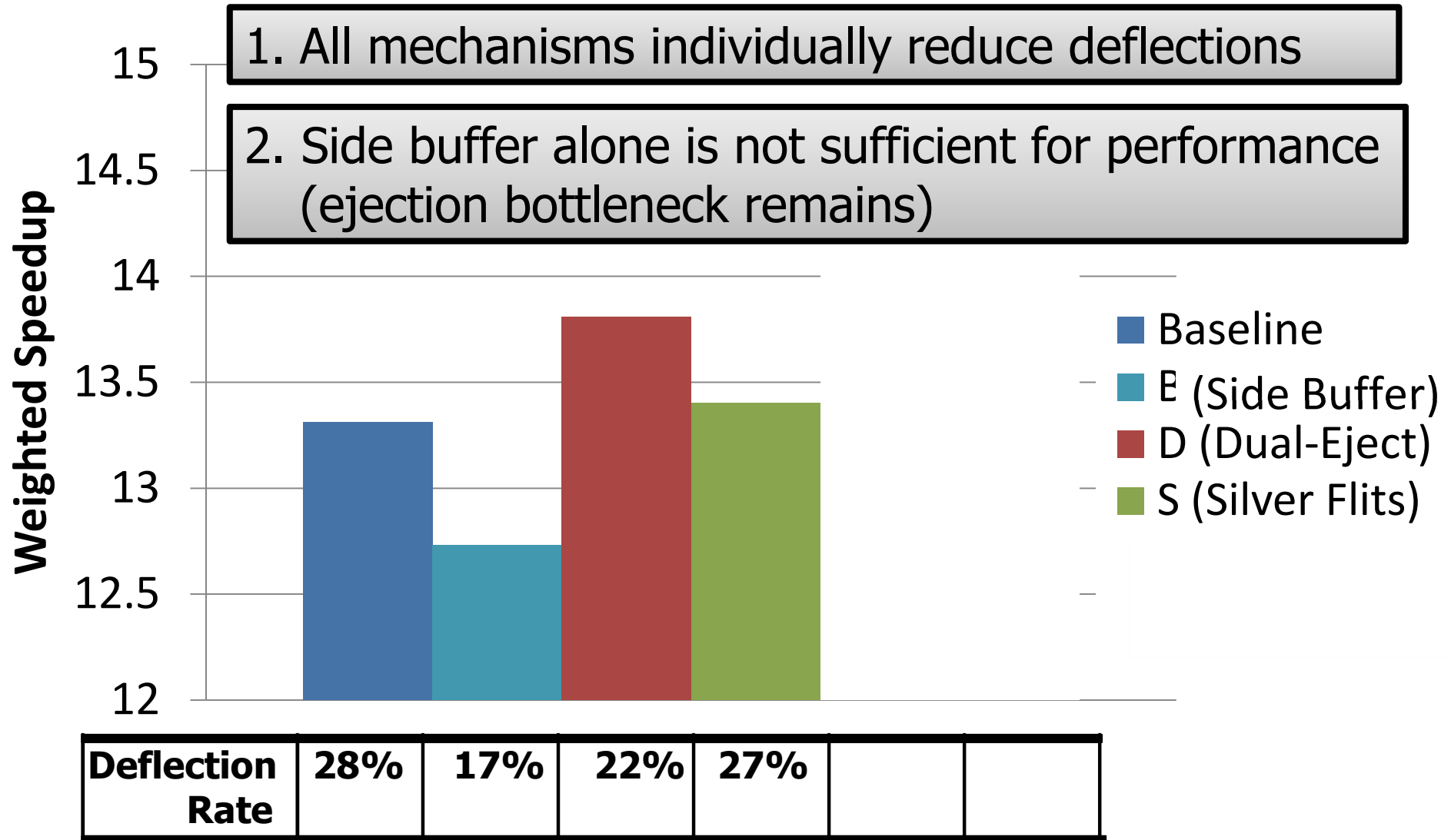



# Reduced Deflections & Improved Perf.

3. Overall, **5.8%** over baseline, **2.7%** over dual-eject by reducing deflections **64%** / **54%**

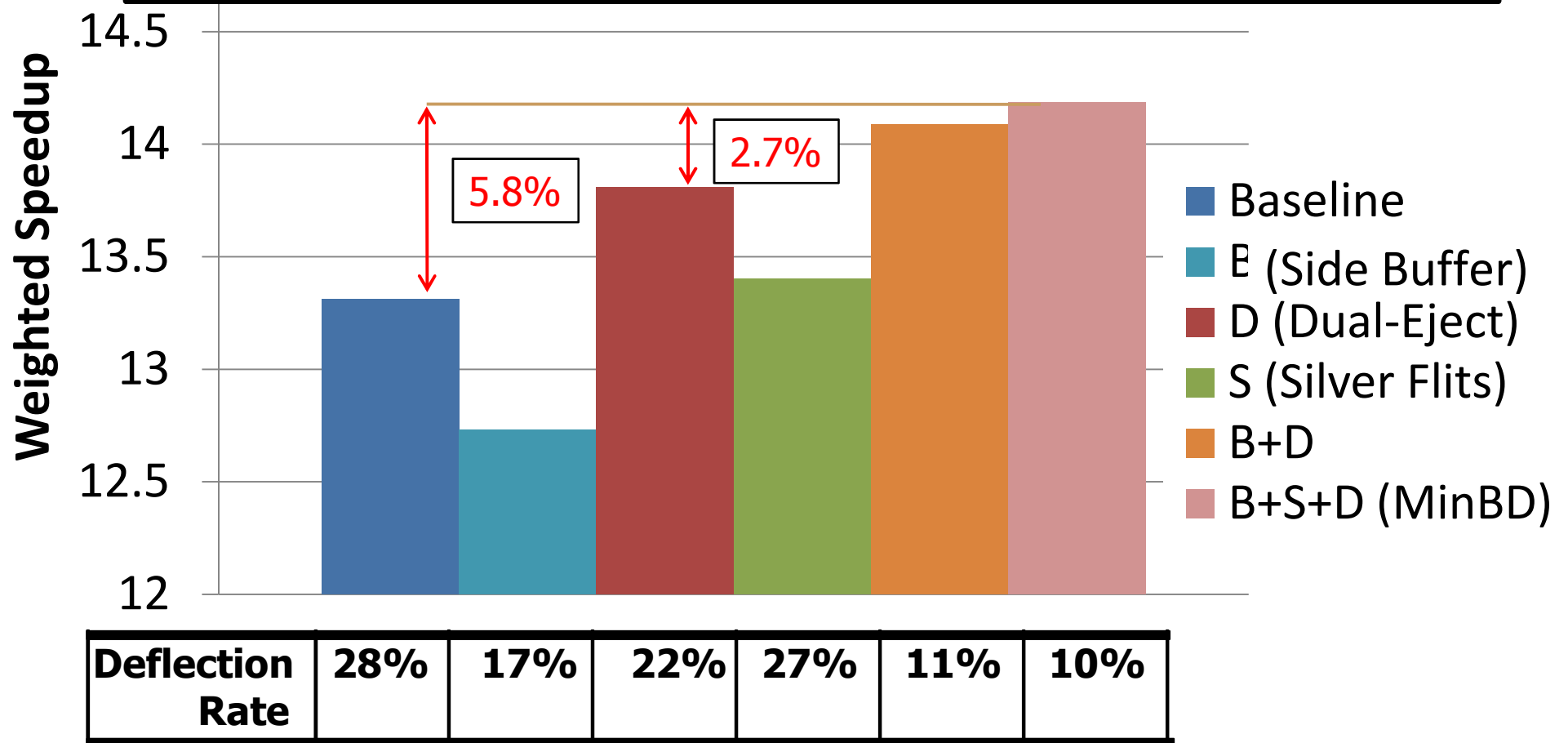

# Overall Performance Results

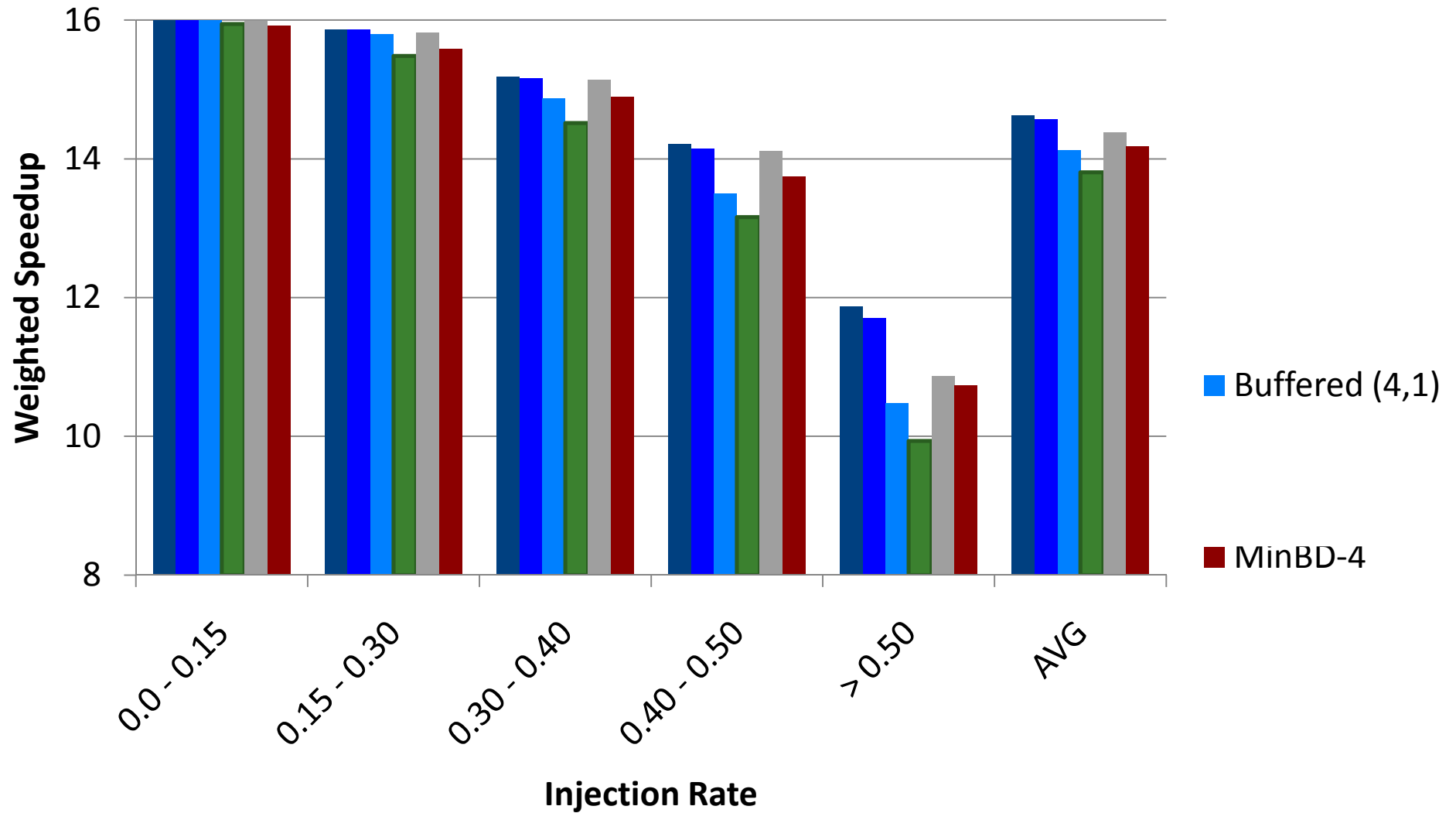

# Overall Performance Results

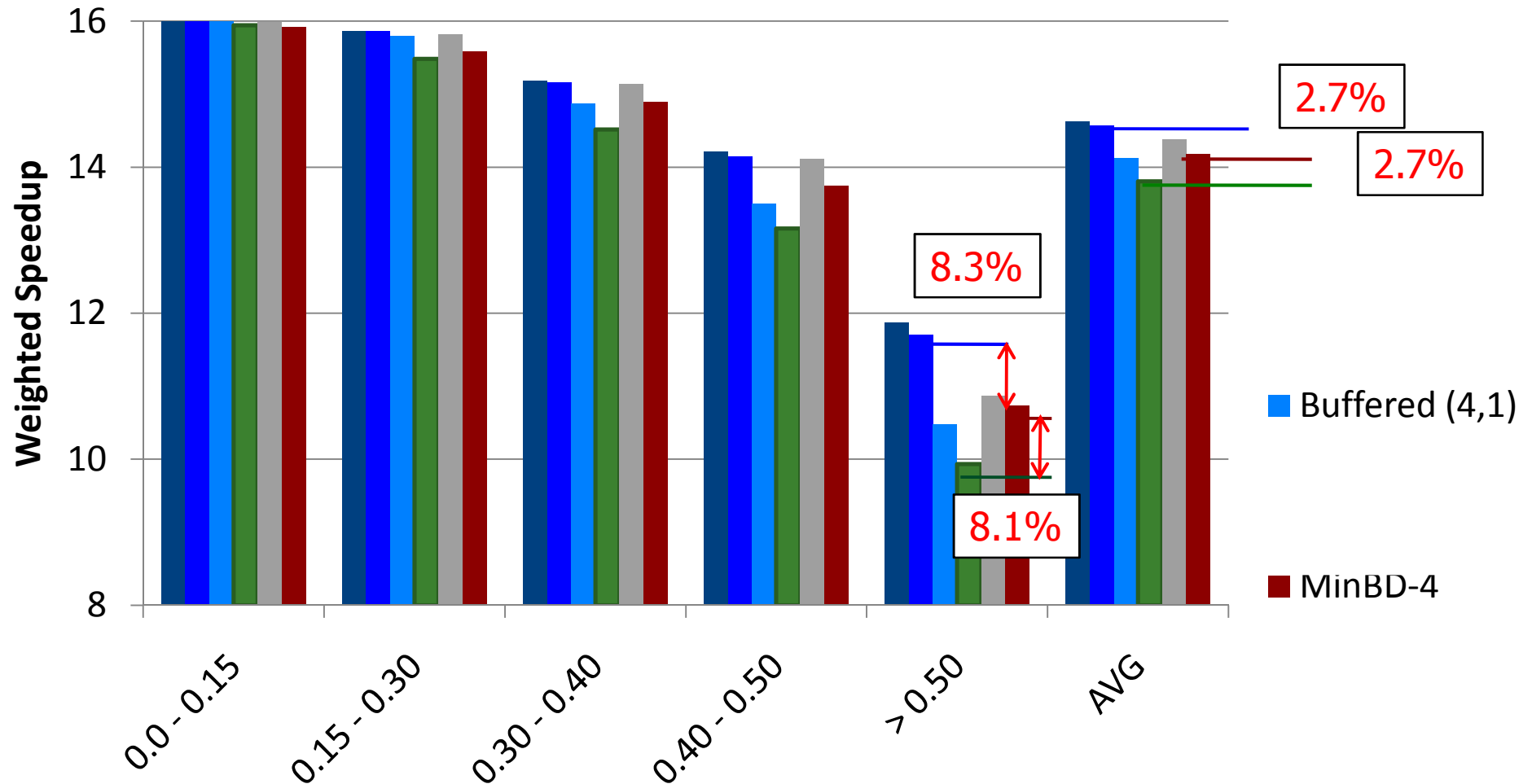

- Improves **2.7%** over CHIPPER (**8.1%** at high load)

- Within **2.7%** of Buffered (4,4) (**8.3%** at high load)

# Overall Performance Results

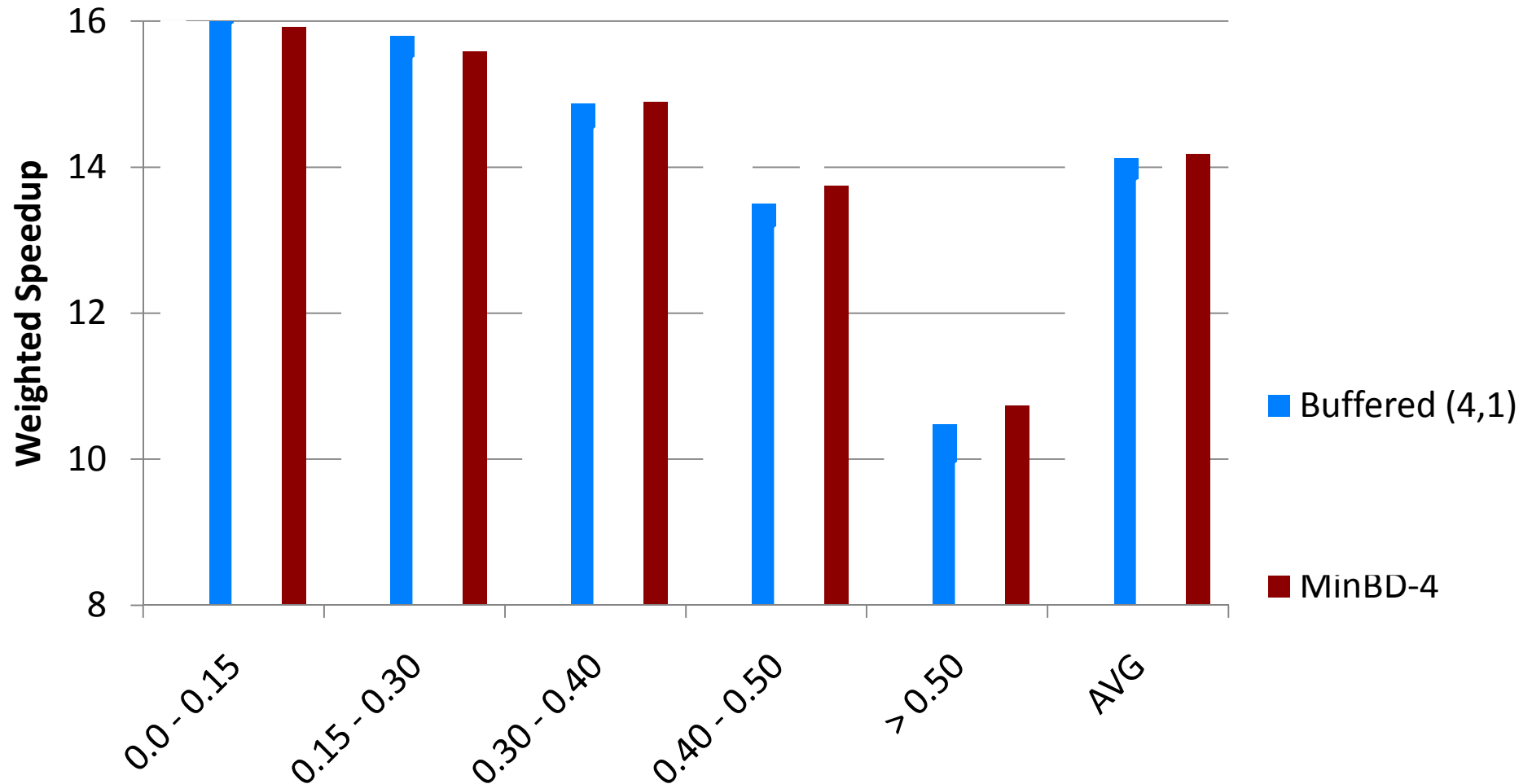

- Similar perf. to Buffered (4,1) @ 25% of buffering space

# Overall Power Results

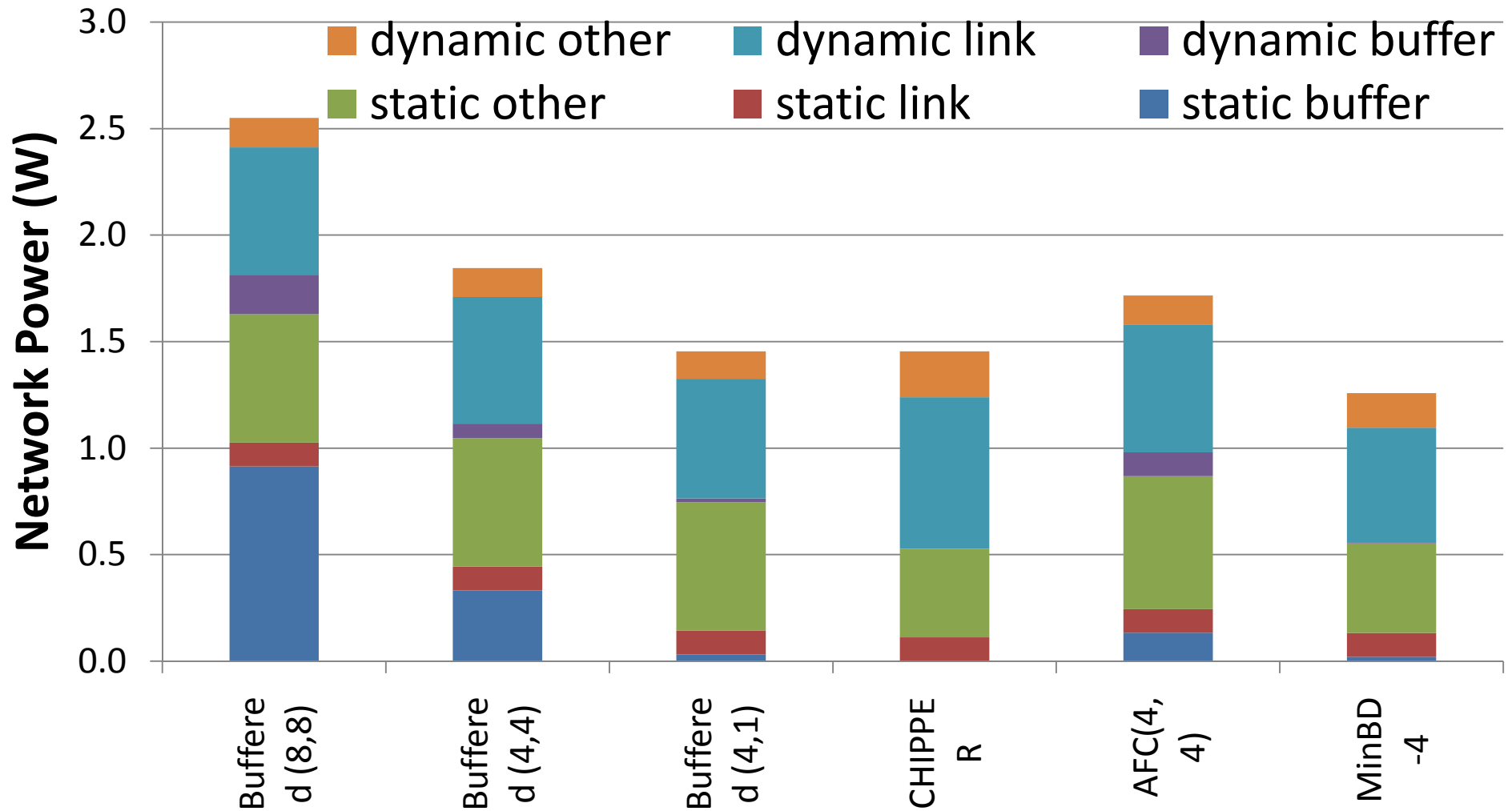

# Overall Power Results

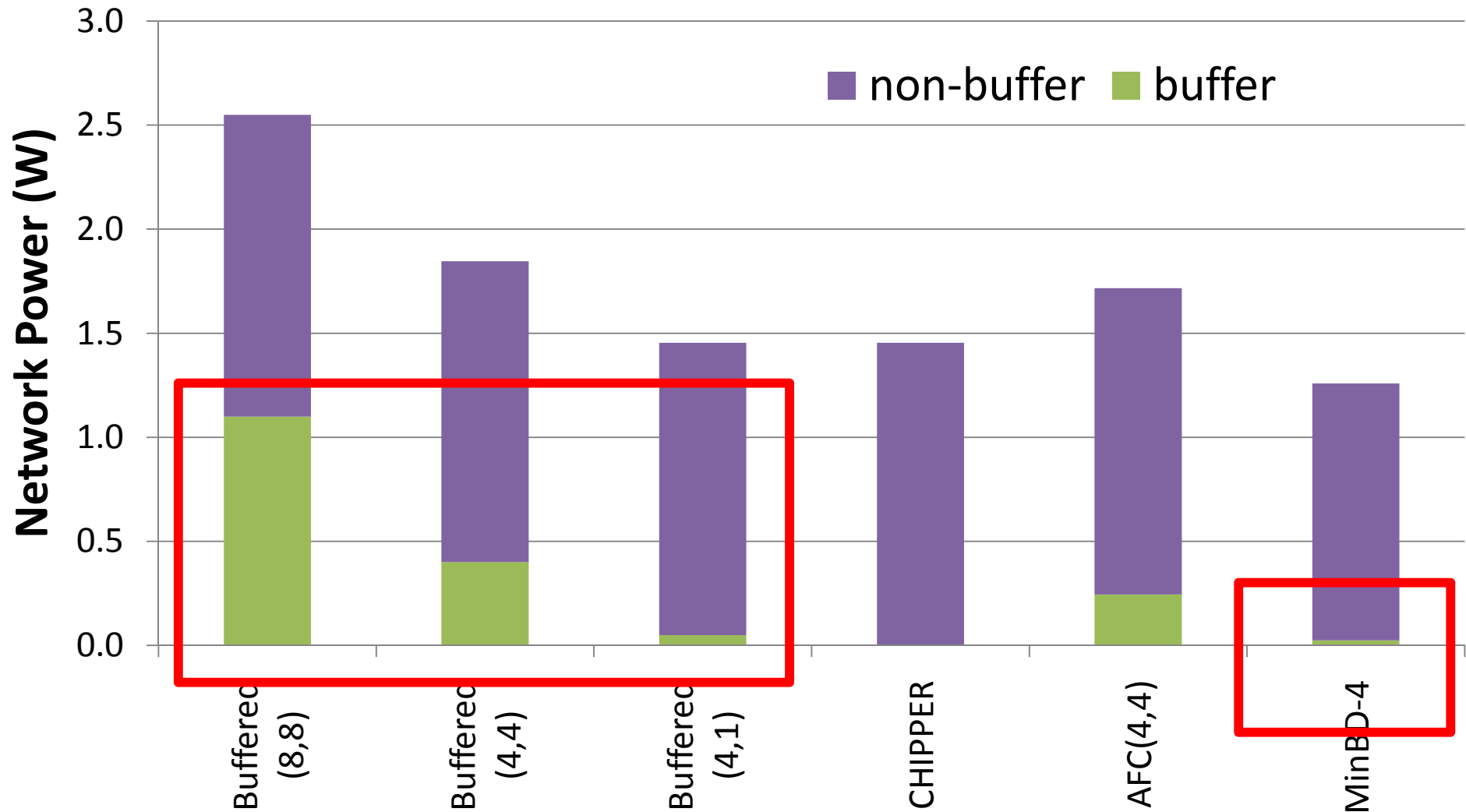

- Buffers are significant fraction of power in baseline routers
- Buffer power is much smaller in MinBD (4-flit buffer)

# Overall Power Results

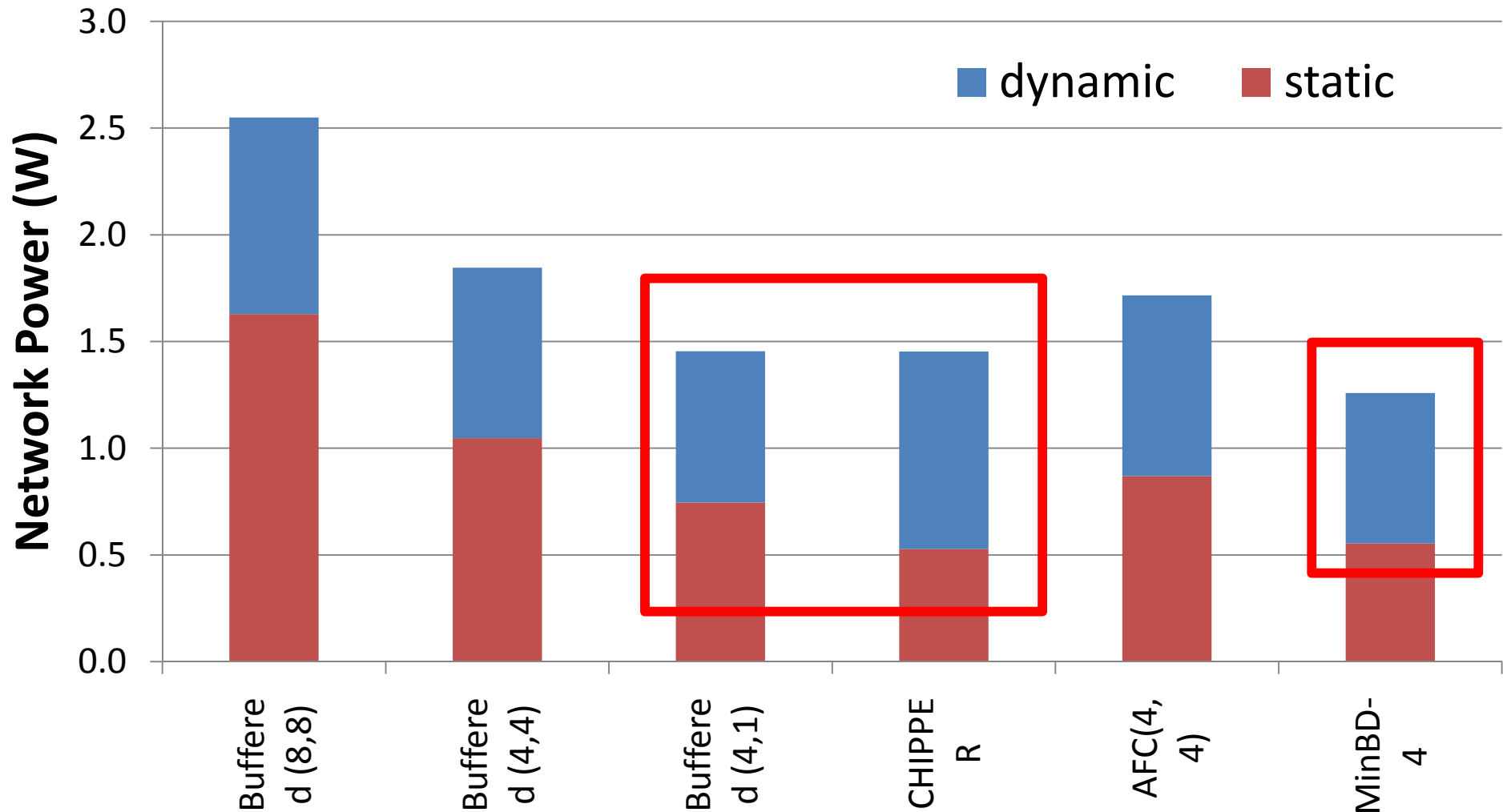

- Dynamic power increases with deflection routing

- Dynamic power reduces in MinBD relative to CHIPPER

# Overall Power Results

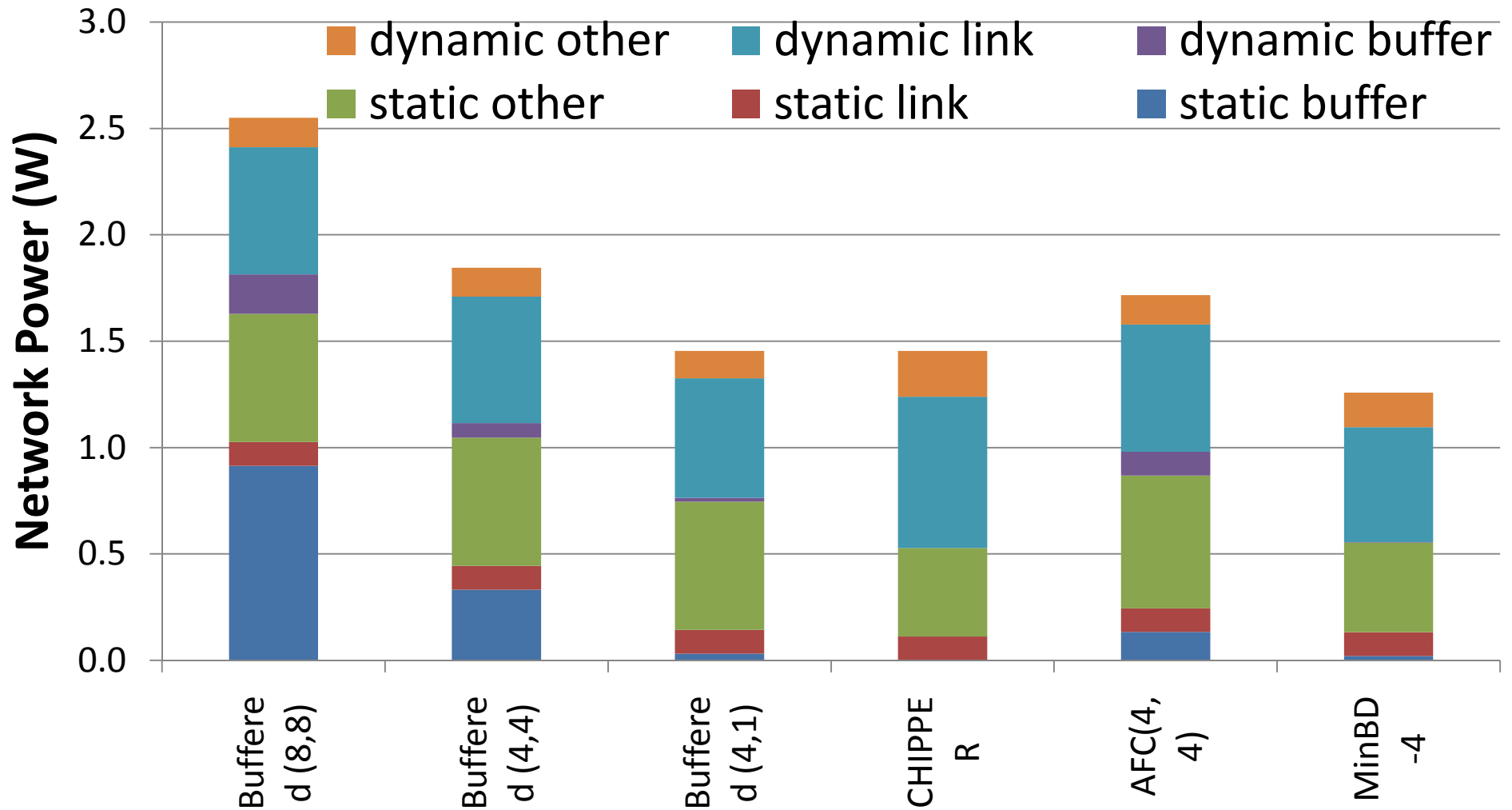



# Performance-Power Spectrum

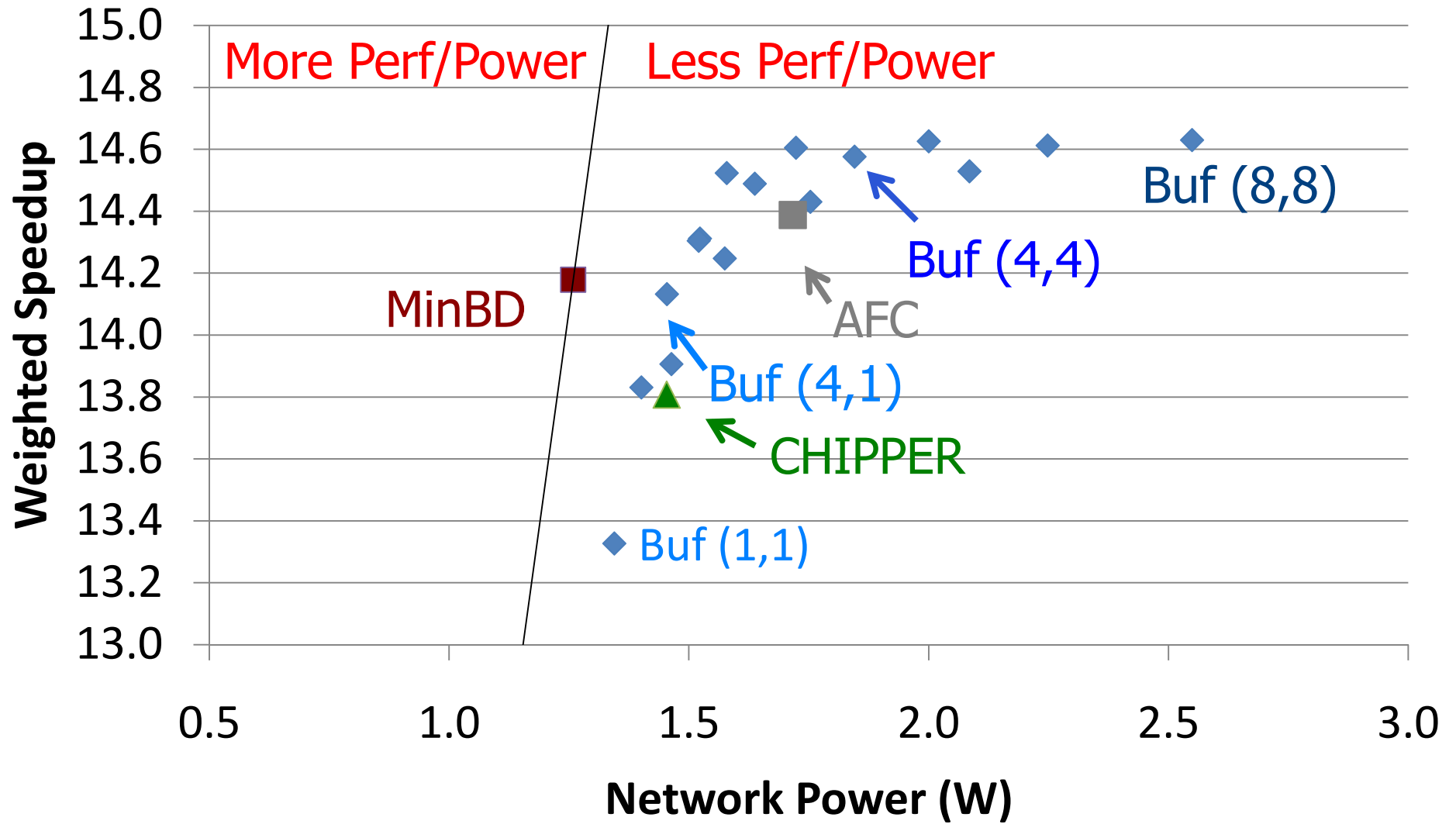

# Performance-Power Spectrum

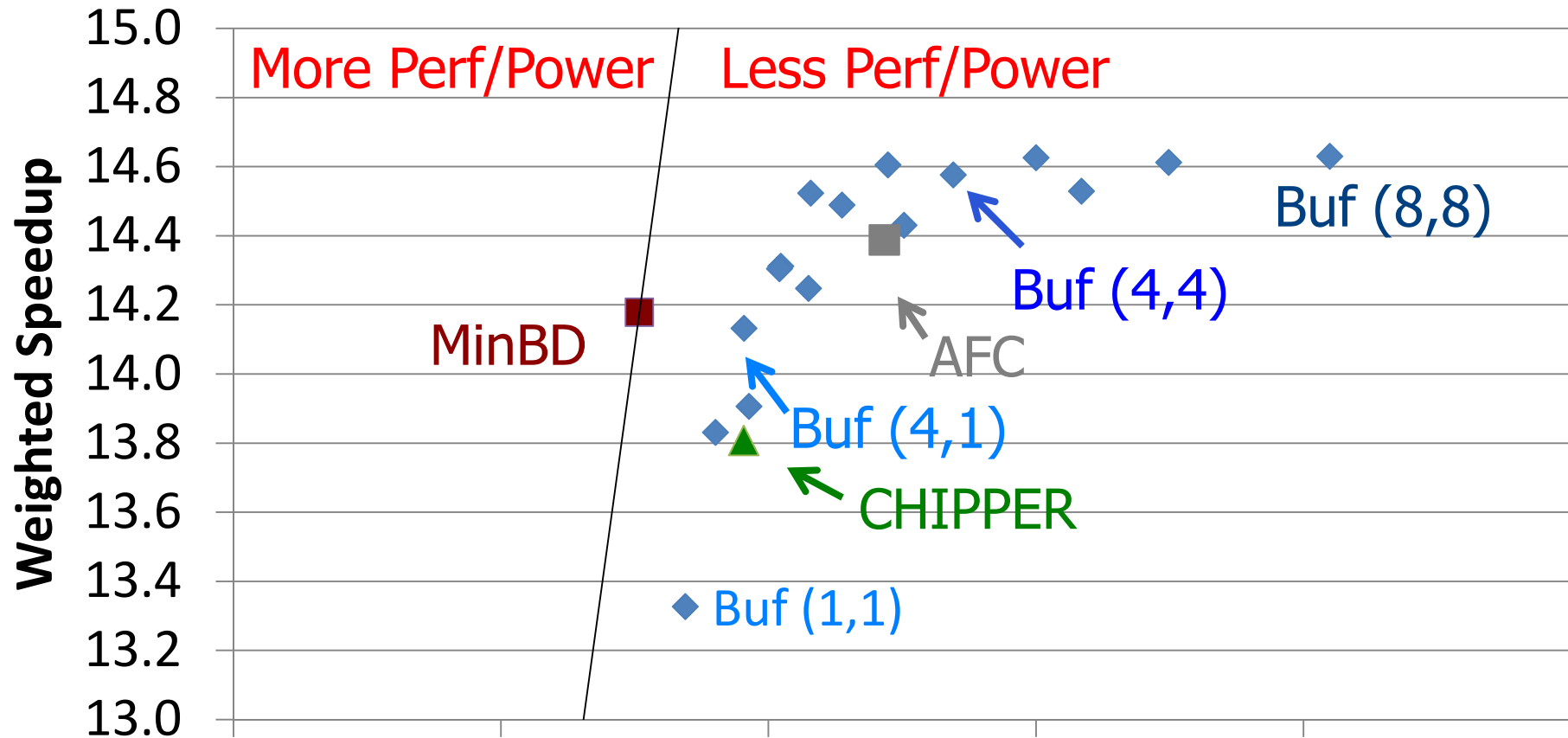

- Most **energy-efficient** (perf/watt) of any evaluated network router design

# Die Area and Critical Path

---

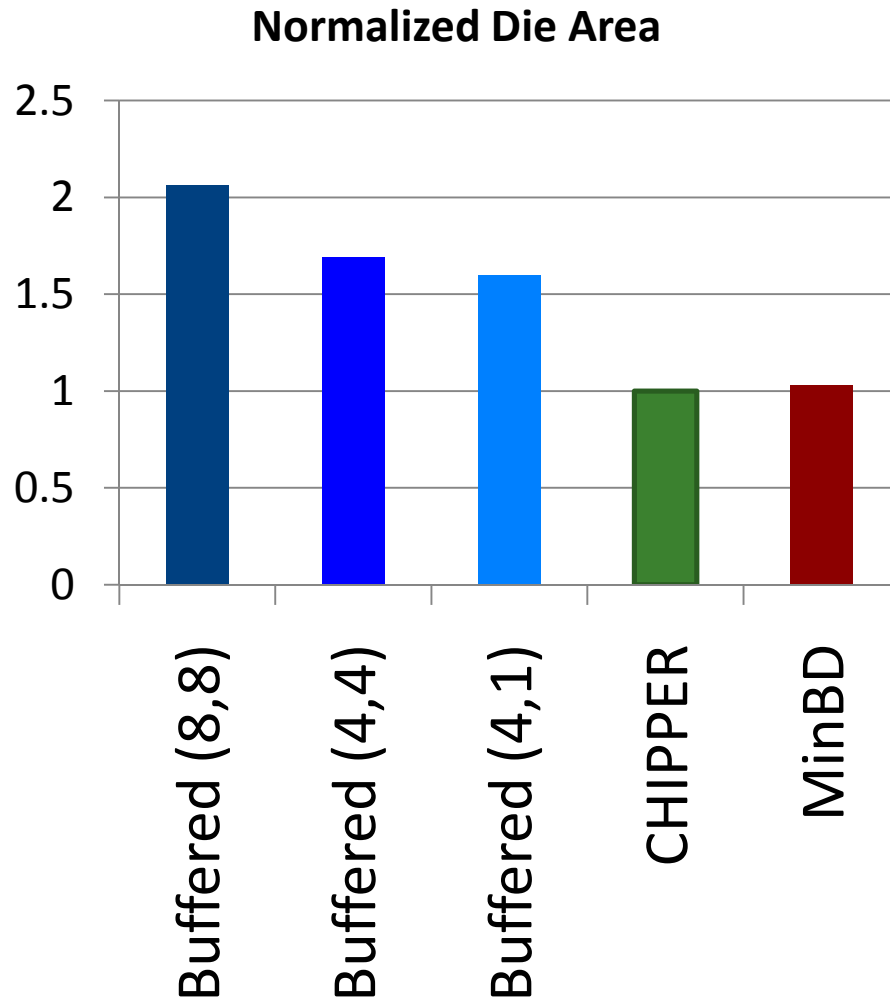

# Die Area and Critical Path

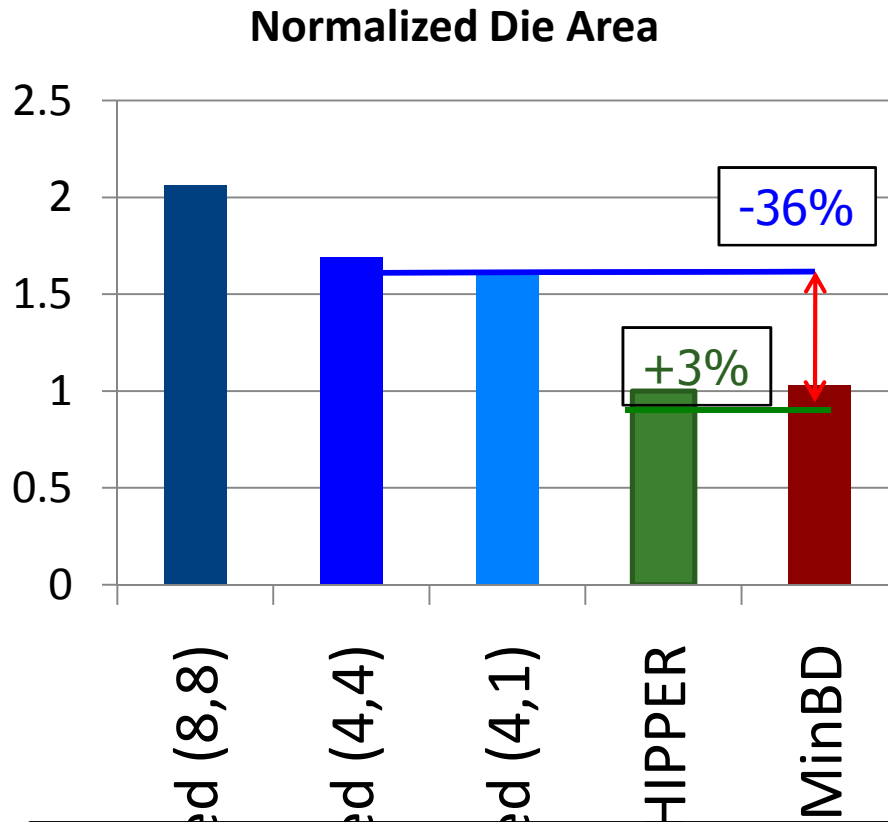

- Only **3%** area increase over CHIPPER (4-flit buffer)
- Reduces area by **36%** from Buffered (4,4)

# Die Area and Critical Path

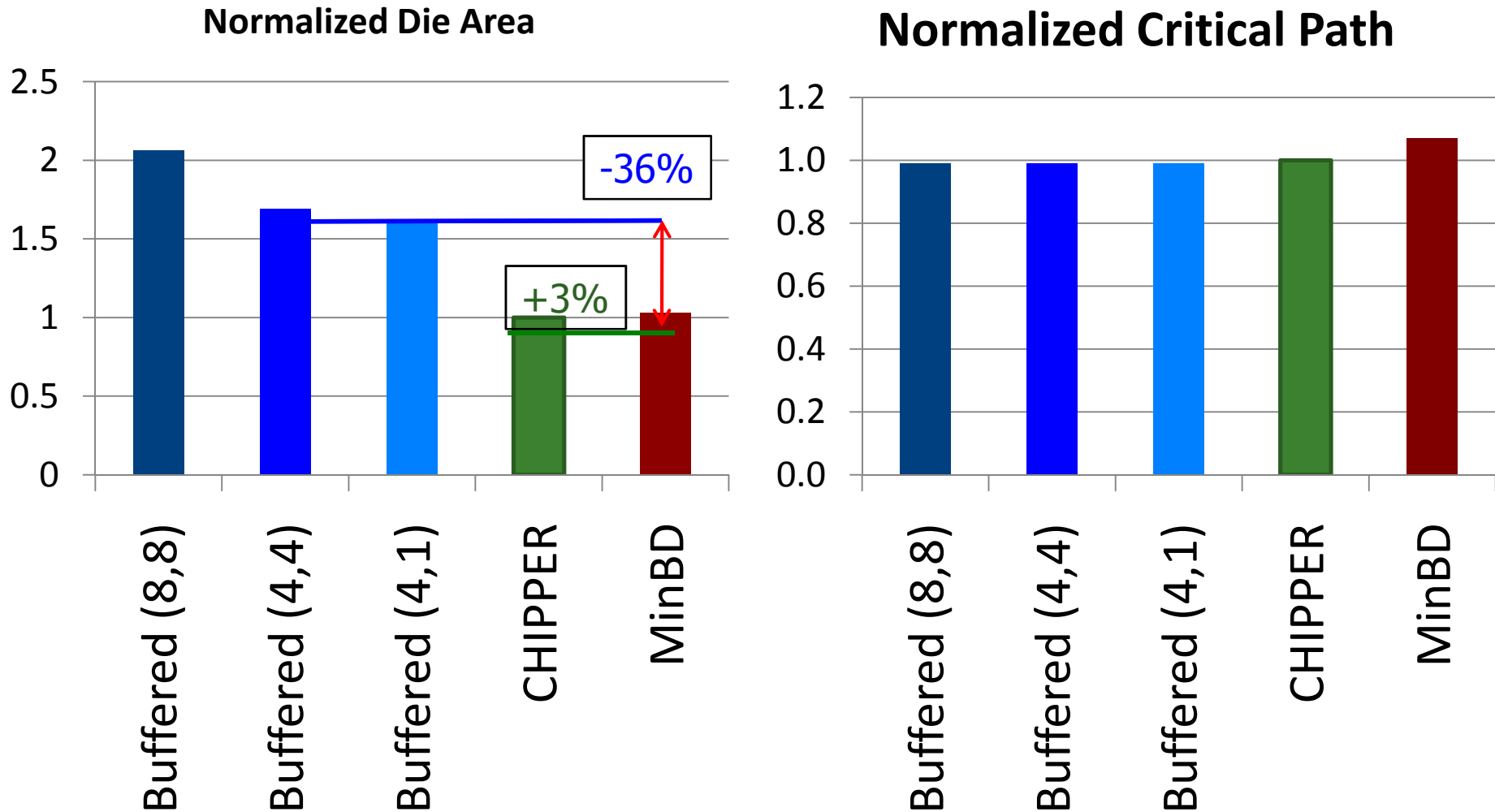

# Die Area and Critical Path

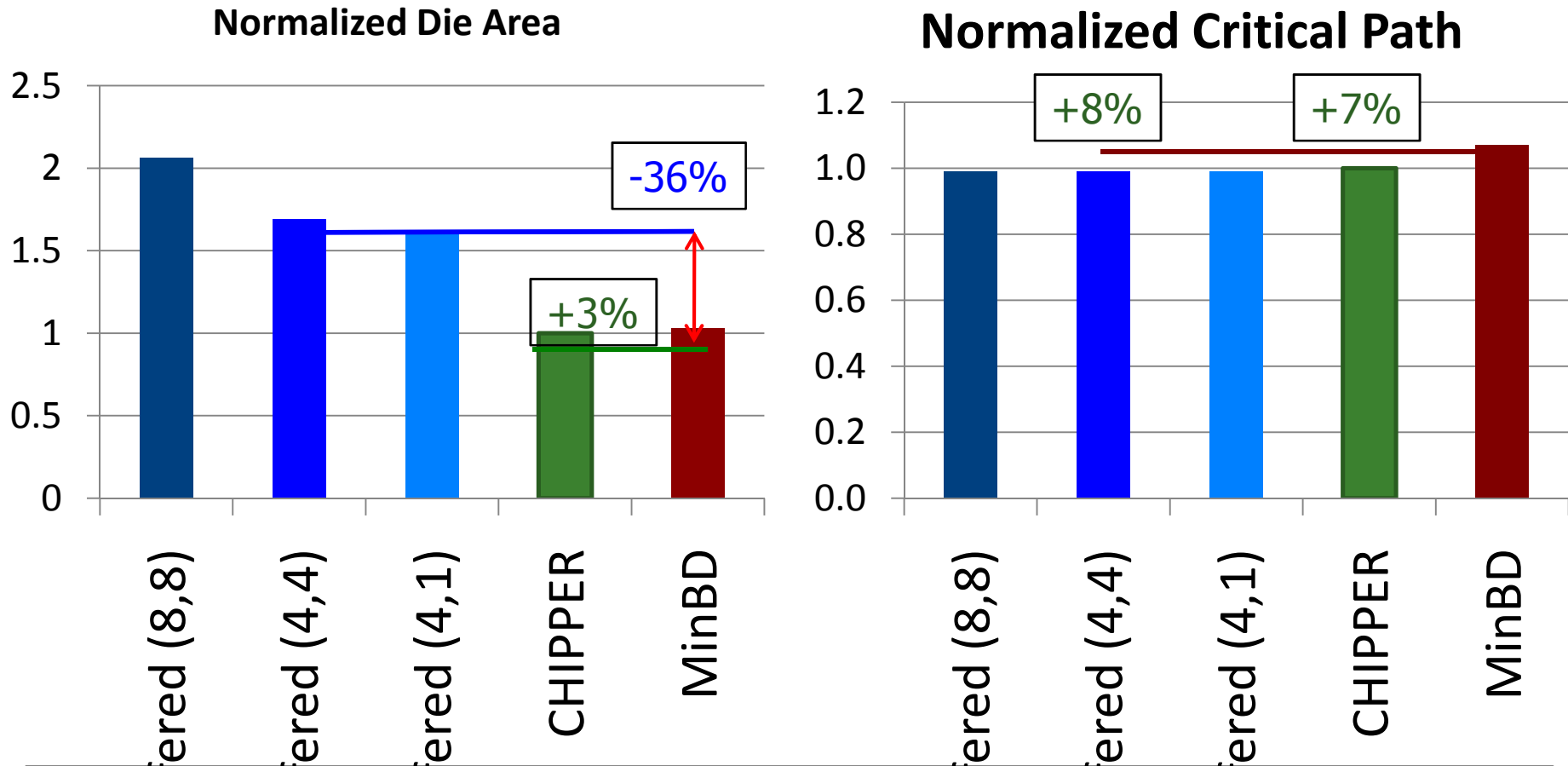

- Increases by **7%** over CHIPPER, **8%** over Buffered (4,4)

# Conclusions

---

- Bufferless deflection routing offers **reduced power & area**
  - But, high deflection rate hurts **performance at high load**
  
  - **MinBD** (Minimally-Buffered Deflection Router) introduces:
    - **Side buffer** to hold **only** flits that would have been deflected
    - **Dual-width ejection** to address ejection bottleneck
    - **Two-level prioritization** to avoid unnecessary deflections
  
  - MinBD yields **reduced power (31%) & reduced area (36%)** relative to **buffered** routers
  - MinBD yields **improved performance (8.1% at high load)** relative to **bufferless** routers → closes half of perf. gap
  
  - MinBD has the **best energy efficiency** of all evaluated designs with **competitive performance**
-

---

**THANK YOU!**



# MinBD: Minimally-Buffered Deflection Routing for Energy-Efficient Interconnect

**Chris Fallin**, Greg Nazario, Xiangyao Yu\*,  
Kevin Chang, Rachata Ausavarungnirun, Onur Mutlu

Carnegie Mellon University

\*CMU and Tsinghua University

**SAFARI** Carnegie Mellon University

---

# BACKUP SLIDES

# Correctness: Golden Packet

---

- The Golden Packet is always prioritized long enough to be delivered (hop latency \* (max # hops + serialization delay))
  - “Epoch length”: e.g. 4x4:  $3 * (7 + 7) = 42$  cycles (pick 64 cyc)
- Golden Packet rotates statically through all packet IDs
  - E.g. 4x4: 16 senders, 16 transactions/sender → 256 choices
- Max latency is GP epoch \* # packet IDs
  - E.g.,  $64 * 256 = 16K$  cycles
- Flits in Golden Packet are arbitrated by sequence # (total order)

# Correctness: Retransmit-Once

---

- Finite reassembly buffer size may lead to buffer exhaustion
- What if a flit arrives from a new packet and no buffer is free?
- Answer 1: Refuse ejection and deflect → deadlock!
- Answer 2: Use large buffers → impractical
- **Retransmit-Once** (past work): operate opportunistically & assume available buffers
  - If no buffer space, drop packet (once) and note its ID
  - Later, reserve buffer space and retransmit (once)
- End-to-end flow control provides correct endpoint operation without in-network backpressure

# Correctness: Side Buffer

---

- Golden Packet ensures delivery *as long as flits keep moving*
  - What if flits get “stuck” in a side buffer?
  - Answer: **buffer redirection**
    - If buffered flit cannot re-inject after  $C_{\text{threshold}}$  cycles, then:
      1. Force one input flit per cycle into buffer (random choice)
      2. Re-inject buffered flit into resulting empty slot in network
  - If a flit is golden, it will **never enter a side buffer**
  - If a flit *becomes* golden while buffered, redirection will rescue it after  $C_{\text{threshold}} * \text{BufferSize}$  (e.g.:  $2 * 4 = 8$  cyc)
  - Extend Golden epoch to account for this
-

# Why does Side Buffer Alone Lose Perf.?

---

- Adding a side buffer reduces deflection rate
  - Raw network throughput increases
- But **ejection is still the system bottleneck**
  - Ejection rate remains nearly constant
- Side buffers are utilized → **more traffic in flight**
- Hence, **latency increases** (Little's Law):  $\sim 10\%$

# Overall Power Results

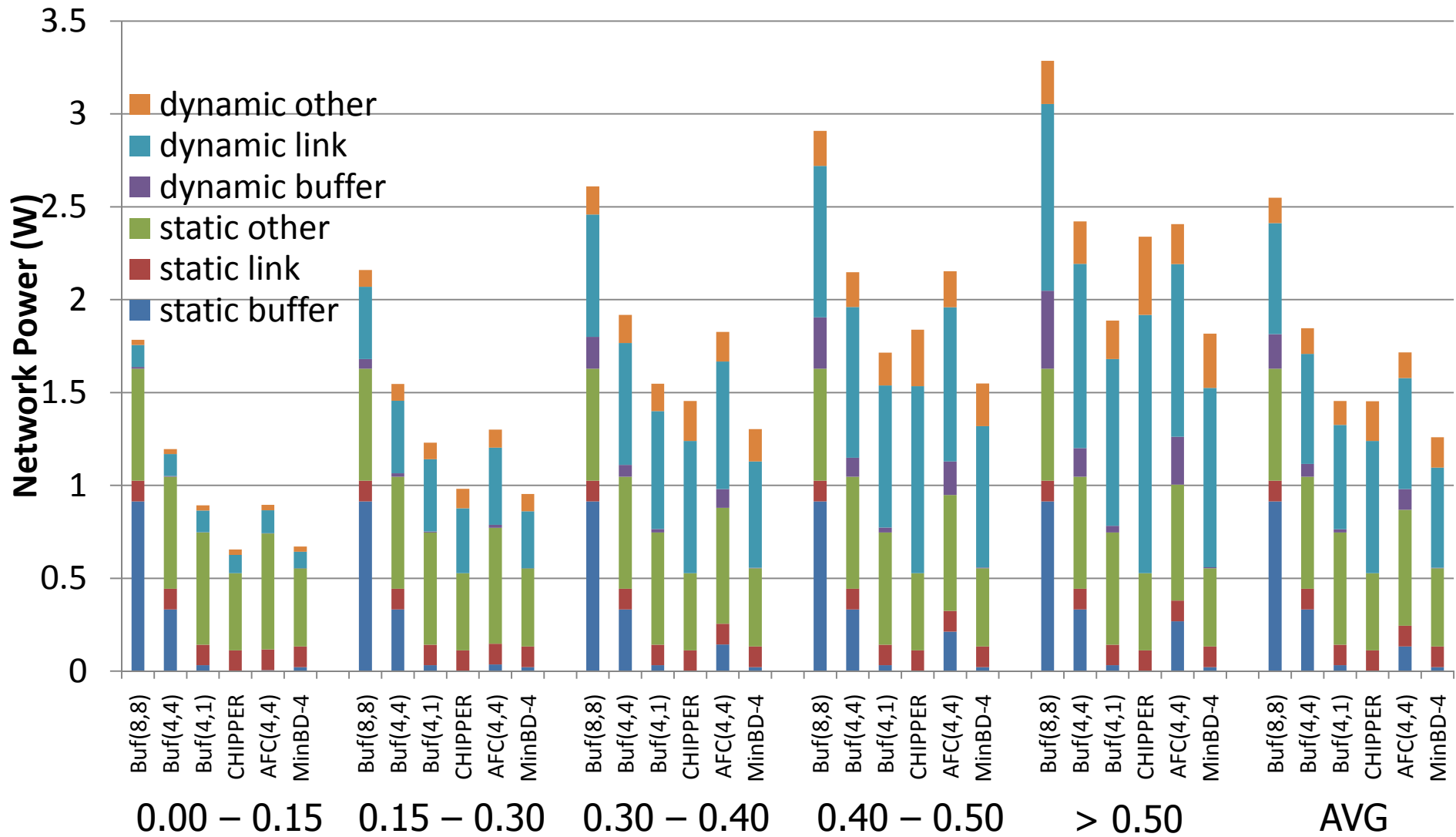

# MinBD vs. AFC

---

## ■ **AFC:**

- ❑ Combines **input buffers** and **deflection routing**
- ❑ In a given cycle, all link contention is handled by **buffers** or by **deflection** (global router mode)
- ❑ Mode-switch is heavyweight (drain input buffers) and takes multiple cycles
- ❑ Router has area footprint of buffered + bufferless, but could save power with power-gating (assumed in Jafri et al.)
- ❑ Better performance at highest loads (equal to buffered)

## ■ **MinBD:**

- ❑ Combines **deflection routing** with a **side buffer**
  - ❑ In a given cycle, some flits are buffered, some are deflected
  - ❑ Smaller router and no mode switching
  - ❑ But, loses some performance at highest load
-



# Related Work

---

- **Baran**, 1964
  - Original “hot potato” (deflection) routing
- **BLESS** (Moscibroda and Mutlu, ISCA 2009)
  - Earlier bufferless deflection router
  - Age-based arbitration → slow (did not consider critical path)
- **CHIPPER** (Fallin et al., HPCA 2011)
  - Assumed baseline for this work
- **AFC** (Jafri et al., MICRO 2010)
  - Coarse-grained bufferless-buffered hybrid
- **SCARAB** (Hayenga et al., MICRO 2009), **BPS** (Gomez+08)
  - Drop-based deflection networks
  - SCARAB: dedicated circuit-switched NACK network